



Hultafors



TO RELY ON



HV 60



Hultafors

30°
UV
TOLERANCE
10.75
mm to

“Function and precision that you can feel in your hand.”

Ask any craftsman you like. They’ll tell you – “If you want the real deal, it has to be Hultafors.” You can rest assured that by choosing a Hultafors tool, you are getting a tool that delivers the best possible function, reliability and precision. Tools that can take all the hard knocks, are durable and, more to the point, feel right in your hand.

The reason for this is quite simple. We develop all our products in conjunction with professionals. We understand their work situation and listen to their needs. They are involved in testing the products until everyone is happy with the results. For us, this is the only way of being sure that our tools actually work and make your job easier.

The knowledge we have of your workday and that of other craftsmen is undeniably unique. As is our extensive experience. It all began in 1883, when Karl-Hilmer Johansson Kollén designed what is now the world-renowned folding rule. Since then, we have spent 125 years developing and manufacturing tools for tradesmen. Tools that you can rely on in all situations, every day.



Håkan Carlsson
Commercial Product Manager





ESSENTIALS EQUIPMENT CON

Folding rules	6
Tape measures	10
Marking measures	16
Spirit levels	18
Squares	30
Marking	32
Levelling rods	36

Hammers	38
Sledges	46
Axes	52
Loose handles	60

Craftsman's knives	62
Snap-off knives	68
Chisels.....	70

Saws	74
Clamps	78

Wrecking bars	84
Pry bars	87

Tool carriers	90
---------------------	----

Advertising print	94
-------------------------	----

Measuring
and marking

Chopping
and striking

Knives and
chisels

Saws and
clamps

Pry and
wrecking bars

Tool carriers

Advertising
print



Developed with experience. Experience, know-how and development together with users have made our folding rules the most popular models on the market. You know when you are holding a folding rule from Hultafors. A craftsman can always tell.

Manufactured to stringent requirements. During production, each folding rule is photographed twice using a high-speed camera. On the first pass, we sort out rules containing knots and cross-grain wood. After grading, the rule is photographed for a second time, during which the execution and position of the scale is checked. Folding rule manufacture is governed by a quality system certified in accordance with ISO 9001.

Choose the right material. Our standard folding rules are made from downy birch. However, we also produce rules in fibreglass-reinforced polyamide and anodised aluminium, allowing you to choose the material that is the best fit for your job.

Accurate measurement – EU Class III.

All our wood, fibreglass and aluminium folding rules are calibrated to the very highest levels of accuracy and are compliant with EU requirements for “Class III, articulated measuring rods”. This means that a 2 m folding rule has a maximum deviation of ± 1.4 mm and a 1 m folding rule a deviation of ± 1 mm. The measurement over an articulated joint has a deviation of no more than ± 0.5 mm.

Folding rule 59

A Hultafors classic – a must for every craftsman. Traditionally manufactured from downy birch with Swedish steel joints, affording thin sections and great flexibility. Metric scale in black on both sides, and red decimetre figures.

- Type approved as per EU Class III.
- Coated with a water-based protective lacquer for increased resistance to dirt and moisture.
- The joints are heat-treated, epoxy coated and oiled at three points to ensure first-class performance.
- Each folding rule section is checked twice during the production process using high-speed cameras.



Ref. no.	Model	Length	Parts	Width	Qty/pack
100004	59-2-10	2 m	10	17 mm	10 pcs
100005	59-2-10	2 m	10	17 mm	50 pcs
100104	59-2-12	2 m	12	17 mm	10 pcs
100105	59-2-12	2 m	12	17 mm	50 pcs
100204	59-1-6	1 m	6	17 mm	10 pcs

Folding Rule 559, Contact-meter

A folding rule made from downy birch with Swedish steel joints, affording thin sections and great flexibility. Internal metric scale on both sides depicted in black (centimetres/millimetres) and red (decimetres). Used for measuring directly on surfaces.

- Type approved as per EU Class III.
- Coated with a water-based protective lacquer for increased resistance to dirt and moisture.
- The joints are heat-treated, epoxy coated and oiled at three points to ensure first-class performance.
- Each folding rule section is checked twice during the production process using high-speed cameras.



Ref. no.	Model	Length	Parts	Width	Qty/pack
101804	559-2-10	2 m	10	17 mm	10 pcs



1. Folding Rule 559
2. Folding Rule 59

Shrinkage Folding Rule 590

A shrinkage folding rule manufactured from downy birch with Swedish steel joints, affording thin sections and great flexibility. Metric scale on one side and a shrinkage scale in red figures on the reverse. Uses include the setting of casting moulds.

- Coated with a water-based protective lacquer for increased resistance to dirt and moisture.
- The joints are heat-treated, epoxy coated and oiled at three points to ensure first-class performance.
- Each folding rule section is checked twice during the production process using high-speed cameras.



Ref. no.	Model	Length	Parts	Width	Shrinkage	Qty/pack
103104	590-2-10 1%	2 m	10	17 mm	1%	10 pcs
103504	590-1-6 2%	1 m	6	17 mm	2%	10 pcs

Folding Rule 61

A classic folding rule manufactured from downy birch with Swedish steel joints, affording thin sections and great flexibility. Scale with black figures on both sides, metric along the bottom edge and British imperial along the top edge.

- Coated with a water-based protective lacquer for increased resistance to dirt and moisture.
- The joints are heat-treated, epoxy coated and oiled at three points to ensure first-class performance.
- Each folding rule section is checked twice during the production process using high-speed cameras.



Ref. no.	Model	Length	Parts	Width	Qty/pack
100504	61-2-10	2 m	10	17 mm	10 pcs
100505	61-2-10	2 m	10	17 mm	50 pcs
100704	61-1-6	1 m	6	17 mm	10 pcs

Folding Rule 82

A folding rule manufactured from downy birch with Swedish steel joints, affording thin sections and great flexibility. Metric scale on one side and Danish inches on the other.

- Coated with a water-based protective lacquer for increased resistance to dirt and moisture.
- The joints are heat-treated, epoxy coated and oiled at three points to ensure first-class performance.
- Each folding rule section is checked twice during the production process using high-speed cameras.



Ref. no.	Model	Length	Parts	Width	Qty/pack
101504	82-2-12	2 m	12	17 mm	10 pcs



Folding Rule G59

Folding rule made from fibreglass-reinforced polyamide, affording increased resistance to moisture. Metric scale in black on both sides, and red decimetre figures.

- Increased resistance to moisture.
- Foil-embossed scale provides increased protection against wear.
- Type approved as per EU Class III.

Ref. no.	Model	Length	Parts	Width	Colour	Qty/pack
200004	G 59-2-10 GU	2 m	10	15 mm	Yellow	10 pcs
200064	G 59-2-10 VI	2 m	10	15 mm	White	10 pcs
200104	G 59-2-12 GU	2 m	12	15 mm	Yellow	10 pcs
200204	G 59-1-6 GU	1 m	6	15 mm	Yellow	10 pcs
200304	G 59-1-10 GU	1 m	10	13 mm	Yellow	10 pcs
200364	G 59-1-10 VI	1 m	10	13 mm	White	10 pcs



Folding Rule GE59

Folding rule made from fibreglass-reinforced polyamide, affording increased resistance to moisture. End-piece of stainless steel on the first and last stick which will increase protection against wearing. Metric scale in black on both sides, and red decimetre figures.

- Increased resistance to moisture.
- End-piece in stainless steel.
- Foil-embossed scale provides increased protection against wear.
- Type approved as per EU Class III.

Ref. no.	Model	Length	Parts	Width	Colour	Qty/pack
200664	GE 59-2-10 VI	2 m	10	15 mm	White	10 pcs
200604	GE 59-2-10 GU	2 m	10	15 mm	Yellow	10 pcs

Patent application filed EP 08152208.8



Folding Rule G61

Folding rule made from fibreglass-reinforced polyamide, affording increased resistance to moisture. Scale with black figures on both sides, metric along the bottom edge and British imperial along the top edge.

- Increased resistance to moisture.
- Foil-embossed scale provides increased protection against wear.

Ref. no.	Model	Length	Parts	Width	Colour	Qty/pack
200404	G 61-2-10 GU	2 m	10	15 mm	Yellow	10 pcs
200504	G 61-1-6 GU	1 m	6	15 mm	Yellow	10 pcs



Folding Rule A59

A folding rule made from anodised aluminium with galvanised steel joints. Metric graduations in black on both sides. Good resistance to moisture, heat and wear.

- Anodised aluminium with galvanised steel joints affords increased protection against corrosion.
- Highly resistant to moisture, heat and wear.
- Type approved as per EU Class III.

Ref. no.	Model	Length	Parts	Width	Qty/pack
150003	A 59-2-10	2 m	10	15 mm	5 pcs
150103	A 59-1-6	1 m	6	15 mm	5 pcs



Folding Rule A61

A folding rule made from anodised aluminium with galvanised steel joints. Scale with black figures on both sides, metric along the bottom edge and British imperial along the top edge. Good resistance to moisture, heat and wear.

- Anodised aluminium with galvanised steel joints affords increased protection against corrosion.
- Good resistance to moisture, heat and wear.

Ref. no.	Model	Length	Parts	Width	Qty/pack
150203	A 61-2-10	2 m	10	15 mm	5 pcs
150303	A 61-1-6	1 m	6	15 mm	5 pcs



Choose the right measuring tape! Our measuring tapes are available in a wide array of materials, designs and lengths, allowing you to choose the tape that is the best fit for your job.

Better accuracy. Hultafors measuring tapes are graduated primarily using inkjet technology. This affords a level of accuracy that makes our long and short tapes compliant with EU Class I requirements.

Changing tape length. Major temperature changes can have a significant effect on the length of a steel tape measure. All tolerances quoted here apply at 20 °C, so it is important to be aware of the measurement deviations for various temperatures.



Protection against rust and chemicals. Whether you work outdoors, in damp environments or where there is a risk of exposure to hazardous chemicals, we have a measuring tape for you.

Good grip. Being able to keep a good grip of your tools is always important, including measuring tapes. Our longest measuring tapes feature stable and solid handles. The smaller tapes are designed for hand-held use, with some having rubber fittings that provide a more secure and comfortable grip.

TAPE MEASURES WITH PRECISION.

The most important consideration when choosing a tape measure is precision. And, of course, whether the tape is a smart and adroit tool to use on the job. We place considerable emphasis on these considerations during the manufacturing process and have introduced a quality system that is certified in accordance with ISO 9001.

The majority of our measuring tapes are graduated using inkjet technology. By doing so, we achieve a high level of precision and achieve EU Class I, the most exact tolerance class, on both our short and long measuring tapes. Once graduated, we coat each tape with a layer of matt polyester lacquer that has an anti-reflective effect.



TAPE MEASUREMENT ACCURACY – EU CLASS I AND II.

Measurement accuracy is a very important feature of a tape measure. It is measured and stated in the form of a tolerance class. In Europe, we normally classify measuring tapes in EU Class I and EU Class II. The accuracy is measured at 20 °C and 50 N pull force for steel tape and 20 °C and 20 N pullforce for fibreglass tape.

STEEL TAPE MEASURE PRODUCTION TOLERANCES

Total length (m)	Class I (mm)	Class II (mm)
2	±0.3	±0.7
3	±0.4	±0.9
5	±0.6	±1.3
8	±0.9	±1.9
10	±1.1	±2.3
15	±1.6	±3.3
20	±2.1	±4.3
25	±2.6	±5.3
30	±3.1	±6.3
50	±5.1	±10.3
100	±10.1	±20.3

Offset for measurements (including end hook):
Class I: 0.1 mm, Class II: 0.2 mm.

CHANGING LENGTHS.

Often we experience significant temperature differences between summer and winter, differences that affect the length of a steel tape measure. All tolerances quoted here apply at 20 °C, so it is important to be aware of the measurement deviations for various temperatures.

LENGTH CHANGE FOR A STEEL TAPE MEASURE FOR TEMPERATURE DEVIATIONS FROM 20°C

ΔT	10°C	20°C	30°C
Length (m)	Length change (±mm)		
2	0.2	0.5	0.7
3	0.4	0.7	1.1
5	0.6	1.2	1.9
8	1.0	2.0	3.0
10	1.2	2.5	3.7
20	2.5	5.0	7.4
30	3.7	7.4	11.2
50	6.2	12.4	18.6
100	12.4	24.8	37.2

Length change ΔL is calculated using the formula $\Delta L = L \times \Delta T \times \alpha$
L = tape measure length, ΔT = temperature difference from 20°C.
 α = length enlargement coefficient (1.24×10^{-5}).

Example: If outdoor temperature is -10°C, the difference will be -30°C and so, for an 8 m long steel tape measure, the change in length will be -3.0 mm.

BLADE TYPES

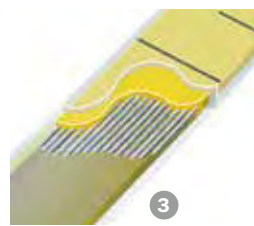

1. Lacquered steel tape – an impact resistant steel tape covered by an anti-corrosion phosphorous layer that is then painted yellow or white. The scale is protected by a coating of matt polyester lacquer. Can withstand contact with most common solvents, but should not be folded. Also available in stainless steel, making the tape highly resistant to corrosion and wear.

2. Nylon coated steel tape – a steel tape covered by an anti-corrosion phosphorous layer and then painted yellow. The scale is protected by a nylon coated. Treated with an extra thick nylon membrane to make the tape really durable. Withstands contact with the majority of chemicals, solvents and other liquids. Can also be bent, twisted and crushed without any problem.

3. Fibreglass tape – a tape measure made from fibreglass threads cast in plastic. Can withstand contact with the majority of chemicals, moisture, water and temperature fluctuations. A fibreglass tape can be bent, is lighter and more flexible to work with. The tape is non-conductive and is therefore safe to use when working in close proximity to sources of electricity.

4. Stainless steel tape – a premium quality deep etched stainless steel blade. Suitable for use in areas where solvents and chemicals are heavily used. (TR range only).

LONG TAPE MEASURES

1. Type A start. The scale starts 100 mm in from the outer edge of the end hook. Used primarily on long tape measures that can measure longer distances and normally require two people to operate. Available on PL, PC and TR tape models.

2. Type B start. The scale starts where the hook attaches to the tape. Ideally suited for solo measurement applications. Available on CC, CC F and SY models.

3. Type C start. The scale starts at the outer edge of the end hook. Ideally suited for solo measurement applications. Available on model PL, YL and PC tapes.

SHORT TAPE MEASURES

4. The scale starts immediately at the end fitting. Ideally suited for both internal and external measurement. Available on model BT, PR and SL tapes.

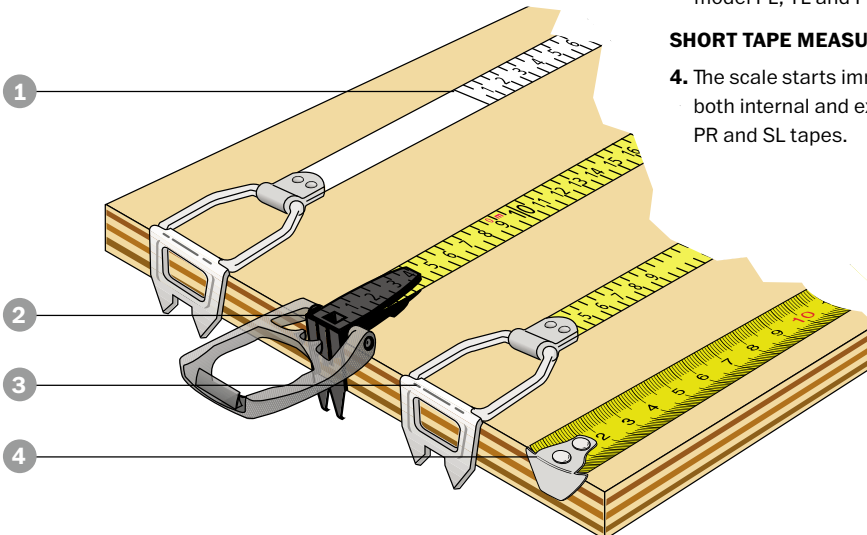

Short Tape Steel BT

Tape with rubber protection at all impact points and a high impact case made of ABS plastic. Yellow steel blade graduated using highly accurate inkjet print with a matt finish allowing reflection-free reading. Rubber end-hook with clearance for internal and external measurement and integrated bump stop for blade return protection.

- Unique belt clip with a quick release function that allows the tape to be released with one hand.
- Internal measurements can be taken by simply adding 100 mm.
- Ergonomic thumb brake for easy blade locking.
- Clear-view end-hook for reading right up to the tip of the blade.

Ref. no.	Model	Length	Class	Graduation	Blade width	Spare blade	Qty/pack
356123	BT 5M	5 m	I	mm	19 mm	356111	2 pcs
356103	BT 5M	5 m	I	mm	19 mm	356111	5 pcs
356223	BT 8M	8 m	I	mm	25 mm	356211	2 pcs
356203	BT 8M	8 m	I	mm	25 mm	356211	5 pcs

Registered Community Design No. 000003413-0001
Patent No. EP 1585935, EP 1505892, EP 1527316



Short Tape Steel PR

Tough tape with ergonomic grip, rubber coated button and brake pad area, with a high impact case made of ABS plastic. Yellow, wear resistant blade graduated using highly accurate inkjet print. Smooth blade return action and bump stop with anti-wear function.

- Type approved as per EU Class I.
- Metal hole hanger for strap enabling safe work at heights.
- Strong stainless steel end-hook with reinforcement plate.
- Distinct brake causing no blade movement.
- The blade can be replaced and is available as a spare.

Ref. no.	Model	Length	Class	Graduation	Blade width	Spare blade	Qty/pack
350103	PR 3M	3 m	I	mm	19 mm	350111	2 pcs
350203	PR 5M	5 m	I	mm	19 mm	350211	2 pcs
350303	PR 8M	8 m	I	mm	25 mm	350311	2 pcs

Patent application filed EP 11169527.6



Short Tape Steel SL

Slim model with a high impact case made of ABS plastic. Yellow, wear resistant blade graduated using inkjet print. Smooth blade return action and bump stop with anti-wear function.

- Type approved as per EU Class I.
- Metal hole hanger for strap enabling safe work at heights.
- Strong stainless steel end piece with reinforcement plate.
- Distinct brake causing no blade movement.
- The blade can be replaced and is available as a spare.

Ref. no.	Model	Length	Class	Graduation	Blade width	Spare blade	Qty/pack
351103	SL 3M	3 m	I	mm	16 mm	351111	2 pcs
351203	SL 5M	5 m	I	mm	19 mm	351211	2 pcs

Patent application filed EP 11169527.6



Bench Tape Steel TRB

This tape measure is designed to be fitted to cutting benches. It is produced in corrosion protected steel, graduated in millimetres and has a blade width of 13 mm. Available with scale running right to left or left to right.

- The scale is protected by a nylon coating, making the tape particularly wear-resistant.
- The tape is protected against corrosion and can withstand contact with the majority of chemicals and solvents.
- Type approved as per EU Class II.

Ref. no.	Model	Length	Class	Blade width	Scale	Qty/pack
357003	TRB 3 HV	3 m	II	13 mm	right-left	5 pcs
357103	TRB 3 VH	3 m	II	13 mm	left-right	5 pcs
357403	TRB 10 HV	10 m	II	13 mm	right-left	5 pcs
357503	TRB 10 VH	10 m	II	13 mm	left-right	5 pcs





Small case



Medium case



Large case



X-Large case



Long Tape Steel CC

Tape with a unique one hand grip for each case size enabling optimal handling. White, impact resistant steel tape, graduated using highly accurate ink jet print. Protected by an additional transparent polyester top coating and a high impact case made of ABS plastic – made to take a beating. Unique loop with added features and a type B tape start. Mouth-piece with anti-wear function. Hole hanger for strap enabling safe work at heights.

- Type approved as per EU Class I.
- The steel tape can withstand gentle bending, but should not be folded.
- Scale is protected by a matt polyester lacquer that also reduces glare.
- The tape is protected against corrosion and can withstand contact with moisture and the majority of solvents.
- Tape measure CC in medium size case has quick gear function 3:1.

Ref. no.	Model	Length	Class	Graduation	Blade width	Case	Spare blade	Qty/pack
390103	CC 10M	10 m	I	mm	10 mm	Small	390109	2 pcs
390203	CC 20M	20 m	I	mm	10 mm	Small	390209	2 pcs
390303	CC 30M	30 m	I	mm	10 mm	Medium	390309	2 pcs
390503	CC 50M	50 m	I	mm	13 mm	Large	390409	2 pcs

Registered Community Design No. 001328140-1/4



Long Tape Fibreglass CC F

Tape with a unique one hand grip for each case size enabling optimal handling. Yellow fibreglass, 13 mm blade width, with a high impact case made of ABS plastic – made to take a beating. Unique loop with added features and a type B tape start. Mouth-piece with anti-wear function. Hole hanger for strap enabling safe work at heights.

- Type approved as per EU Class II.
- Fibreglass tape is strong, flexible and can be bent without any problem.
- The tape can withstand moisture, temperature fluctuations, the majority of chemicals and is electrically non-conductive.

Ref. no.	Model	Length	Class	Graduation	Blade width	Case	Spare blade	Qty/pack
391103	CC 10FM	10 m	II	cm	13 mm	Large	391109	2 pcs
391423	CC 15FMD	15 m	II	cm	13 mm	Large	391429	2 pcs
391203	CC 20FM	20 m	II	cm	13 mm	Large	391209	2 pcs
391303	CC 30FM	30 m	II	cm	13 mm	X-Large	391309	2 pcs

*391423 with diameter graduation.
Registered Community Design No. 001328140-1/4

Long Tape Steel SY

Yellow, impact resistant steel tape measure, 13 mm blade width. The tape also has a thick nylon coating for additional durability, type approved as per EU class 1. Impact resistant ABS frame with rubber over mould protection. Easy clean blade feed with side flush apertures. Scaled diameter blade drum for balanced rewind speed. Press button firm blade lock with simple lock release.

- Right and left hand flip-out ergonomic rewind handle and low friction action for smooth rewind.
- Integral ground spike for end-hook anchoring.
- Corrosion resistant triple action end-hook.
- Rubber grip top handle and lower base grip.
- Press button firm blade lock with simple lock release.

Ref. no.	Model	Length	Class	Graduation	Spare blade	Qty/pack
353401	SY 30M B	30 m	I	mm	-	1 pcs
353501	SY 50M B	50 m	I	mm	-	1 pcs

Registered Community Design No. 000605126-0001
Patent application filed EP 07700348.1
Patent application filed EP 07700346.5

Long Tape Fibreglass PC

Yellow fibreglass tape measure, 13 mm blade width, highly flexible tape with extra thick coating, offering superior resistance to scuffing and marking, ABS plastic frame. Available with either type A or C tape starts.

- Fibreglass tape is strong, flexible and can be bent without any problem.
- The tape can withstand moisture, temperature fluctuations, the majority of chemicals and is electrically non-conductive.
- Type approved as per EU Class II.
- ABS plastic makes the frame both light and durable.



Ref. no.	Model	Length	Class	Graduation	Spare blade	Qty/pack
352601	PC 30M A	30 m	II	cm	352611	1 pcs
352651	PC 30M C	30 m	II	cm	-	1 pcs
352701	PC 50M A	50 m	II	cm	352711	1 pcs
352751	PC 50M C	50 m	II	cm	-	1 pcs

Long Tape Steel PL

Yellow, impact resistant steel tape measure, 10 mm blade width, graduated using highly accurate inkjet print, with an extra thick nylon coating for added protection, with an ABS plastic frame. Available with either type A or C tape starts.

- This steel tape can be bent and twisted without any problem, but must not be folded.
- The scale is protected by a nylon coating, making the tape particularly wear-resistant.
- The tape is protected against corrosion and can withstand contact with the majority of chemicals and solvents.
- Type approved as per EU Class II.
- ABS plastic makes the frame both light and durable.



Ref. no.	Model	Length	Class	Graduation	Spare blade	Qty/pack
352401	PL 30M A	30 m	II	mm	352411	1 pcs
352451	PL 30M C	30 m	II	mm	-	1 pcs
352501	PL 50M A	50 m	II	mm	352511	1 pcs
352551	PL 50M C	50 m	II	mm	-	1 pcs
352581	PL 100M A	100 m	II	mm	-	1 pcs
352591	PL 100M C	100 m	II	mm	-	1 pcs

Long Tape Steel YL

Yellow, impact resistant steel tape measure, 13 mm blade width, graduated using highly accurate inkjet print, with an extra thick nylon coating for added protection. Type C tape start.

- This steel tape can be bent and twisted without any problem, but must not be folded.
- The scale is protected by a nylon coating, making the tape particularly wear-resistant.
- The tape is protected against corrosion and can withstand contact with the majority of chemicals and solvents.
- Type approved as per EU Class II.



Ref. no.	Model	Length	Class	Graduation	Spare blade	Qty/pack
355451	YL 30M C	30 m	II	mm	-	1 pcs
355551	YL 50M C	50 m	II	mm	-	1 pcs

Long Tape Steel TR

Stainless, deep-etched steel tape measure, 13 mm blade width, graduated in millimetres with an aluminium frame. Type A tape start.

- The tape is made from stainless steel, which makes it resistant to moisture and wear brought about by daily use.
- Highly resistant to corrosion and abrasion.
- Type approved as per EU Class II.



Ref. no.	Model	Length	Class	Graduation	Spare blade	Qty/pack
355581	TR 10M A	10 m	II	mm	355591	1 pcs
355601	TR 20M A	20 m	II	mm	355611	1 pcs
355801	TR 30M A	30 m	II	mm	355811	1 pcs
355901	TR 50M A	50 m	II	mm	-	1 pcs

Long Tape Steel TRT

Stainless, deep-etched steel tape measure, 13 mm blade width, graduated in millimetres with an aluminium frame. The tape has a pointed brass weight on its end and is designed to measure depths in things such as tanks and wells.

- The tape is made from stainless steel, which makes it resistant to moisture and wear brought about by daily use.
- Highly resistant to corrosion and abrasion.
- Type approved as per EU Class II.
- The brass weight is 70 mm long and weighs 280 g.



Ref. no.	Model	Length	Class	Graduation	Spare blade	Qty/pack
355651	TRT 20M	20 m	II	mm	-	1 pcs
355851	TRT 30M	30 m	II	mm	-	1 pcs

MEASURING AND MARKING MADE EASY.

THE UNIQUE MARKING MEASURES from Hultafors have facilitated work for craftsmen for decades. With our latest range of TALMETER marking measures we extend the range of possibilities further. What makes the TALMETER marking measure so special is the fact that you can take a measurement and then mark it directly onto your work-piece. Without even reading off the scale to verify the length. Thanks to the combined measuring and marking edges

and a firm brake you can keep your set measurement and securely transfer it to any object. Over and over again. Furthermore, it is equally simple to take both internal and external measurements, trace arcs and – depending on model – even diameters and circumferences. So go ahead and explore the possibilities. Take your measuring further with a TALMETER marking measure from Hultafors.

Marking Measure TALMETER 2M/3M

White, impact resistant steel tape measure, 16 mm blade width, graduated in millimetres with an ABS plastic case. Combined marking and measurement edges mean that you can quickly and simply measure and mark both internal and external lengths. The tape and extender can be replaced and are available as spare parts.

- Internal and external measurement using etching function.
- Diameter measurement with scale on the reverse side of the tape.
- The TALMETER has a calliper function that is handy to mark out round shapes.
- The scale is always locked in normal position.
- The extender is easy to extend and retract using the grip-friendly sliding carriage.
- 359403 TALMETER 3M VP has the mm and diameter scale on the same front side of the blade.

Ref. no.	Model	Length	Class	Blade width	Spare blade	Qty/pack
359103	TALMETER 2m	2 m	II	16 mm	359111	6 pcs
359203	TALMETER 3m	3 m	II	16 mm	359211	6 pcs
359403	TALMETER 3m VP	3 m	II	16 mm	359411	6 pcs
359003*	MT-SL	-	-	-	-	-

*Model MT-SL is the extender + sliding carriage as spare parts.
Patent application filed EP 08152206.2
Registered Community Design No. 000889928-1/4



Scale TALMETER 2M/3M



Scale TALMETER 3M VP



The number of measurement units that the length comprises can be read from reading the indicators against the scale. However, if it is possible to etch the length directly on the workpiece, actually reading the measurement becomes completely unnecessary.

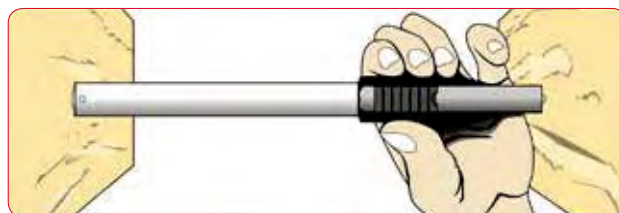

The fold-out extender is designed to make internal measurements just as easy to take as external measurements.



The combined measurement and marking edges allow you to take your measurement and then transfer that measurement to your workpiece.



Measure internal lengths just as quickly and simply as external lengths.



Use as a compass and draw precise arcs with a single hand.



The stiff, yet flexible tape makes it easy to measure diameters and exact circumferences.

The automatic lock ensures that your measured/set lengths are kept in place. You can transfer your measurement to the material you want to cut without taking a reading.

White, hardwearing steel tape, graduated with scales for both internal and external measurement on the top side and a diameter scale on the underside.

The combined marking and measurement edges are used when measuring and marking lengths and for etching arcs.

The fold-out extender makes internal measurements as easy to take as external measurements. It is easy to fold out and lock in position using the grip-friendly sliding carriage.

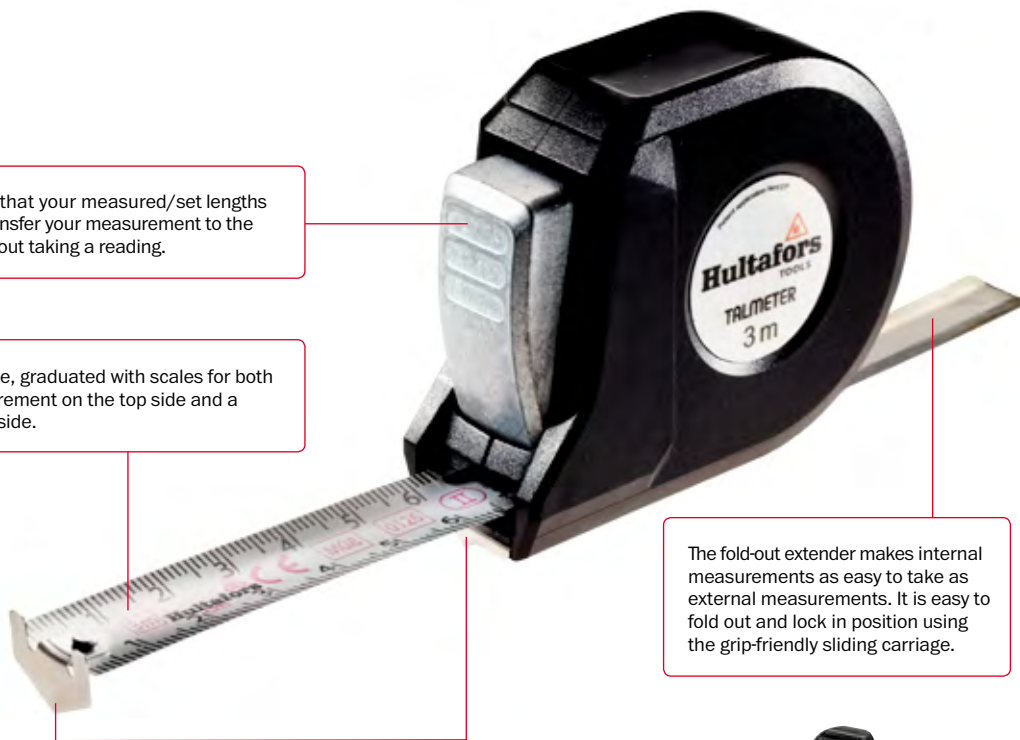

Marking Measure TALMETER 6M

White, impact resistant steel tape measure, 25 mm blade width, graduated in millimetres using inkjet technology with an ABS plastic case. Combined marking and measurement edges mean that you can quickly and simply measure and mark both internal and external lengths. The tape and extender can be replaced and are available as spare parts.

- Internal and external measurement using etching function.
- Unique belt clip with a quick release function that allows the marking measure to be released with one hand.
- Vertical scale on the reverse side of the tape.
- The TALMETER has a caliper function that is handy to mark out round shapes.
- The extender is easy to extend and retract using the grip-friendly sliding carriage.



Ref. no.	Model	Length	Class	Blade width	Spare blade	Qty/pack
359303	TALMETER 6M	6 m	II	25 mm	359311	2 pcs
359003*	MT-SL	-	-	-	-	-

*Model MT-SL is the extender + sliding carriage as spare parts.
 Patent application filed EP 08152206.2
 Registered Community Design No. 001230320-1/2



Measure internal lengths just as quickly and simply as external lengths.

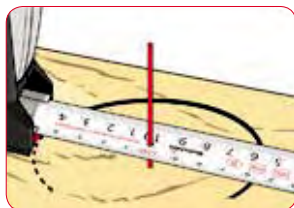

Use as a compass to draw precise arcs with a single hand.



The combined measurement and marking edges allow you to take your measurement and then transfer it to your workpiece using the same measurement edges.



Button with three functions:
 1. Autolock position – tape can be adjusted in and out.
 2. Release position – tape retracts into the housing and is easy to pull out.
 3. Brake position – the tape is locked.



A notch on rear edge of the housing allows the attachment of a safety line.



Unique belt clip with a quick release function that allows the marking measure to be released with one hand.



The belt clip attachment is easy to remove.

Choose the right spirit level! Our range includes spirit levels that are designed for a variety of purposes and work situations. They are made from either aluminium or plastic and are available in a number of different lengths.

Quality marked. To guarantee accuracy, all our spirit levels are manufactured in accordance with a quality system compliant with ISO 9001.

Easy to read. Our spirit levels feature vials made from tough plastic that have a high level of transparency and durability. The fluid inside is a low viscosity oil mixture that is resistant to temperature fluctuations, ultraviolet light and static electricity.



Durable profile. Aluminium gives the profile additional durability without the spirit level becoming too heavy. Profile strength is primarily affected by two factors – the size of the hole for the vial and the thickness of the profile.

High accuracy. The sensitivity of the vial determines how quickly the bubble moves when one end of the spirit level is lifted. In turn, the sensitivity of the vial is determined by its radius. The larger the radius, the easier it is for the air bubble to move and the higher the level of accuracy achieved.



CHOOSE THE RIGHT SPIRIT LEVEL.

We offer a range of spirit levels for all possible work situations. There are spirit levels in aluminium and plastic, specially-adapted and multi-functional. We also produce several that can be equipped with accessories to help you carry out other measurement tasks in your work.

LOW MANUFACTURING TOLERANCE

Manufacturing tolerance is the sum of all faults that may occur during production: the vial's radius and assembly into the profile; the parallelism and straightness of the profile. All spirit levels are checked before leaving the factory. To guarantee accuracy of our spirit levels, we manage our manufacturing process using a quality system that is certified in accordance with ISO 9001.

DURABLE PROFILE

Aluminium gives the profile additional durability without the spirit level becoming too heavy. Profile strength is primarily affected by two factors – the size of the hole for the vial and the thickness of the profile. The larger the hole the less the durability, and the thicker the walls the greater the durability. The length of the spirit level also plays a part – the longer the level, the greater the level of accuracy. However, you must take extra care when using a long spirit level to ensure that the profile does not become warped or distorted. In order to achieve the best possible durability, our spirit levels are exposed to extreme forces in a series of stringent tests.

EASY TO READ LEVELS

In order to make our vials easy to read, we have equipped them with a magnifying lens that makes the movement of the bubble much clearer. In addition, the vial is also produced with a luminescent reflector that means that it is easily readable even when light conditions are not at their best. The vial also has a series of rings inside the shell that makes it easy for you to read and minimises errors. The rings extend around the

entire vial, meaning that the level can be easily read even from below. The liquid in the vial is a coloured low viscosity oil mixture that gives the bubble optimal freedom of movement and makes it easy to read. The liquid is highly resistant to ultraviolet light and fluctuations in temperature. It is also anti-static, i.e. it is not affected by static electricity. This means that our spirit levels are easy to read in the majority of environments and under the most difficult of conditions.

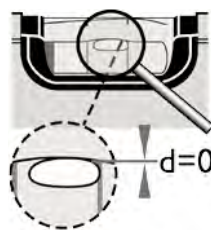

RIGHT SENSITIVITY

The sensitivity of the vial determines how quickly the bubble moves when one end of the spirit level is lifted. If the vial is too sensitive, the level may be difficult to work with. However, the more sensitive the vial, the more accurate your work will be. The radius of the vial determines its accuracy; a larger radius means that the bubble can move more easily. Sensitivity is measured in mm per metre. The parameter is based on a spirit level 1 metre long, and how high one end of the level must be lifted for the bubble to move 2 mm. Certain applications require a higher sensitivity, which is why we produce spirit levels with varying degrees of vial sensitivity.



Radius (mm)	Sensitivity (mm/m)	Model
150	13,3	TVP
200	10	HV
1000	2	Libella
2000	1	MST

Sensitivity is determined by the radius of the vial. The radius is adapted according to the level's area of use.

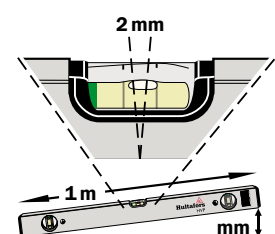

PV SPIRIT LEVEL WITH FOCUS VIAL AND ANTI-SLIP FUNCTION

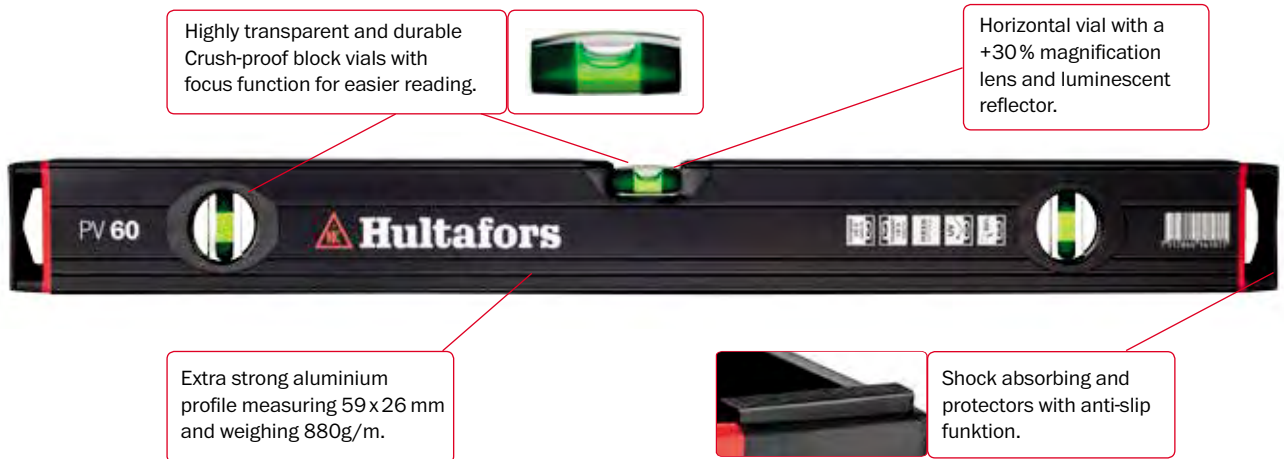

Spirit Level Aluminium PV

Extra strong aluminium profile measuring 59 x 26 mm and weighing 880 g/m. Transparent and durable Crush-proof block vials with temperature-proof vial mountings, highly resistant to ultraviolet light and temperature fluctuations. Horizontal vial with +30% magnification lens and luminescent reflector.

- Tolerance in normal position is ± 0.5 mm/m, upside down ± 0.5 mm/m.
- Focus vials with colour markings for easy reading and with a 200 mm radius giving a sensitivity of 10 mm/m.
- Shock absorbing end protectors with anti-slip function.
- The liquid in the vial is a low viscosity coloured oil mixture that gives the bubble optimal freedom of movement.
- The anti-static properties of the liquid means that the bubble is not affected by static electricity.

Ref. no.	Model	Length	Vials	Qty/pack
414001	PV 40	400 mm	3	1 pcs
414101	PV 60	600 mm	3	1 pcs
414201	PV 80	800 mm	3	1 pcs
414301	PV 100	1000 mm	3	1 pcs
414401	PV 120	1200 mm	3	1 pcs
414501	PV 140	1400 mm	3	1 pcs
414701	PV 200	2000 mm	3	1 pcs



Spirit Level Aluminium HV

Strong, easy to hold aluminium profile measuring 51.5 x 25.3 mm and weighing 630 g/m. Crush-proof block vials that are highly transparent and durable. Horizontal vial with a +30% magnification lens and luminescent reflector. Shock absorbing end protectors and temperature-proof vial mountings.

- Tolerance in normal position is ± 0.5 mm/m, upside down ± 0.75 mm/m.
- The radius of the vial is 200 mm, giving a sensitivity of 10 mm/m.
- The liquid in the vial is a low viscosity coloured oil mixture that gives the bubble optimal freedom of movement.
- Highly resistant to ultraviolet light and temperature fluctuations.
- The anti-static properties of the liquid means that the bubble is not affected by static electricity.

Ref. no.	Model	Length	Vials	Qty/pack
411001	HV 40	400 mm	2	1 pcs
411101	HV 60	600 mm	3	1 pcs
411201	HV 80	800 mm	3	1 pcs
411301	HV 100	1000 mm	3	1 pcs
411401	HV 120	1200 mm	3	1 pcs
411501	HV 150	1500 mm	3	1 pcs
411601	HV 180	1800 mm	3	1 pcs
411701	HV 200	2000 mm	3	1 pcs



Spirit Level Aluminium HVP MAGNET

Strong aluminium profile measuring 49 x 23 mm and weighing 650g/m, with magnets on the underside. Crush-proof block vials that are highly transparent and durable. Horizontal vial with a magnification lens and luminescent reflector.

- Tolerance in normal position is ± 0.5 mm/m, upside down ± 0.75 mm/m.
- The radius of the vial is 200 mm, giving a sensitivity of 10 mm/m.
- The liquid in the vial is a low viscosity coloured oil mixture that gives the bubble optimal freedom of movement.
- Highly resistant to ultraviolet light and temperature fluctuations.
- The anti-static properties of the liquid means that the bubble is not affected by static electricity.

Ref. no.	Model	Length	Vials	Magnets	Qty/pack
400753	HVP Magnet 30	300 mm	2	1	1 pcs
400803	HVP Magnet 40	400 mm	2	2	1 pcs
400903	HVP Magnet 60	600 mm	2	2	1 pcs
401001	HVP Magnet 120	1200 mm	2	4	1 pcs



Spirit Level Aluminium I 360

Strong I-profile made from aluminium measuring 50x23 mm and weighing 640 g/m. Crush-proof tubular vials that are highly transparent and durable. The fully adjustable end vial can be turned 90 degrees for setting or checking slopes.

- Tolerance in normal position is ± 1.0 mm/m.
- The radius of the vial is 200 mm, giving a sensitivity of 10 mm/m.
- The liquid in the vial is a low viscosity coloured oil mixture that gives the bubble optimal freedom of movement.
- Highly resistant to ultraviolet light and temperature fluctuations.
- The anti-static properties of the liquid means that the bubble is not affected by static electricity.

Ref. no.	Model	Length	Vials	Qty/pack
401203	I360	600 mm	3	1 pcs



Spirit Level Aluminium SM

Aluminium profile measuring 49x21 mm and weighing 520 g/m. Crush-proof block vials that are highly transparent and durable..

- Tolerance in normal position is ± 0.75 mm/m, upside down ± 1.0 mm/m.
- The radius of the vial is 200 mm, giving a sensitivity of 10 mm/m.
- The liquid in the vial is a low viscosity coloured oil mixture that gives the bubble optimal freedom of movement.
- Highly resistant to ultraviolet light and temperature fluctuations.
- The anti-static properties of the liquid means that the bubble is not affected by static electricity.

Ref. no.	Model	Length	Vials	Qty/pack
405831	SM 30	300 mm	2	1 pcs
405841	SM 40	400 mm	2	1 pcs
405851	SM 60	600 mm	2	1 pcs
405861	SM 80	800 mm	2	1 pcs
405881	SM 90	900 mm	2	1 pcs
405871	SM 100	1000 mm	2	1 pcs
405921	SM 120	1200 mm	3	1 pcs
405931	SM 150	1500 mm	3	1 pcs
405941	SM 180	1800 mm	3	1 pcs
405951	SM 200	2000 mm	3	1 pcs

Spirit Level Plastic GDS

An impact resistant spirit level made from red polystyrene plastic that withstands temperatures between -15°C and $+60^{\circ}\text{C}$. Crush-proof block vials with very high transparency and durability. Horizontal vial with a magnification lens and luminescent reflector. Easy to clean off cement.

- Tolerance in normal position is ± 1.0 mm/m.
- The radius of the vial is 200 mm, giving a sensitivity of 10 mm/m.
- The liquid in the vial is a low viscosity coloured oil mixture that gives the bubble optimal freedom of movement.
- Highly resistant to ultraviolet light and temperature fluctuations.
- The anti-static properties of the liquid means that the bubble is not affected by static electricity.



Ref. no.	Model	Length	Vials	Qty/pack
401503	GDS 40	400 mm	2	1 pcs
401603	GDS 60	600 mm	2	1 pcs

Torpedo Spirit Level Plastic TVP

An impact resistant spirit level made from red polystyrene plastic that withstands temperatures between -15°C and $+60^{\circ}\text{C}$. Crush-proof block vials with very high transparency and durability. Horizontal vial with luminescent reflector. Has a V-groove in the bottom to allow use on pipes.

- Tolerance in normal position is ± 1.0 mm/m.
- The radius of the vial is 200 mm, giving a sensitivity of 10 mm/m.
- The liquid in the vial is a low viscosity coloured oil mixture that gives the bubble optimal freedom of movement.
- Highly resistant to ultraviolet light and temperature fluctuations.
- The anti-static properties of the liquid means that the bubble is not affected by static electricity.



Ref. no.	Model	Length	Vials	Qty/pack
401803	TVP 25	250 mm	2	5 pcs

Torpedo Spirit Level Plastic TVP Magnetic

An impact resistant spirit level in red ABS plastic with magnets on the underside. Crush-proof tubular vials that are highly transparent and durable.

- Tolerance in normal position is ± 1.5 mm/m.
- The radius of the vial is 150 mm, giving a sensitivity of 13 mm/m.
- The liquid in the vial is a low viscosity coloured oil mixture that gives the bubble optimal freedom of movement.
- Highly resistant to ultraviolet light and temperature fluctuations.
- The anti-static properties.



Ref. no.	Model	Length	Vials	Qty/pack
401853	TVP Magnet 20	200 mm	3	5 pcs



Spirit Level Aluminium MST

The MST level is our strongest and most sensitive spirit level. Made from strong aluminium profile measuring 100 x 25 mm and weighing 1260 g/m. Crush-proof tubular vials that are highly transparent and durable.

- The radius of the vial is 2000 mm, giving a sensitivity of 1 mm/m.
- Tolerance in normal position is ± 0.5 mm/m.
- The liquid in the vial is a low viscosity coloured oil mixture that gives the bubble optimal freedom of movement.
- Highly resistant to ultraviolet light and temperature fluctuations.
- The anti-static properties of the liquid means that the bubble is not affected by static electricity.

Ref. no.	Model	Length	Vials	Qty/pack
402851	MST 150	1500 mm	3	1 pcs
402901	MST 180	1800 mm	3	1 pcs
402911*	L MST	-	-	-

*Model L MST is a loose vial.



Straight Edge Level RS

Made from strong aluminium profile measuring 100 x 18 mm and weighing 870 g/m. Crush-proof block vials that are highly transparent and durable.

- The radius of the vial is 200 mm, giving a sensitivity of 10 mm/m.
- Tolerance in normal position is ± 1.0 mm/m.
- The liquid in the vial is a low viscosity coloured oil mixture that gives the bubble optimal freedom of movement.
- Highly resistant to ultraviolet light and temperature fluctuations.
- The anti-static properties of the liquid means that the bubble is not affected by static electricity.

Ref. no.	Model	Length	Vials	Qty/pack
403001	RS 180	1800 mm	2	1 pcs
403101	RS 200	2000 mm	2	1 pcs
403111	RS 240	2400 mm	2	1 pcs

Spirit Level Aluminium LIBELLA 2000

Libella 2000 has a cast and smooth-finished aluminium housing. Crush-proof block vials with very high transparency, durability, a magnifying lens and luminescent reflector. May be supplemented with rails, extensions and gradient wedges – Libella 2000 has a maximum length of 3100 mm, and the option to check inclinations.

- The radius of the vial is 1000 mm, giving a sensitivity of 2 mm/m.
- Tolerance in normal position is ± 0.25 mm/m, upside down ± 0.75 mm/m.
- The liquid in the vial is a low viscosity coloured oil mixture that gives the bubble optimal freedom of movement.
- Highly resistant to ultraviolet light and temperature fluctuations.
- The anti-static properties of the liquid means that the bubble is not affected by static electricity.



Ref. no.	Model	Length	Other	Vials	Qty/pack
407001	LIBELLA 2000	310 mm	-	2	1 pcs
407011	L 2000	-	Spare vial	-	1 pcs
407831	SP 2000	-	Stress plate with nut	-	1 pcs
407841	SB 600+900	-	Stress block with wing nut	-	1 pcs



Spirit Level Rail Libella

Aluminium spirit level rails with grooves for simple and stepless fitting on Libella 2000. With rails and extensions, LIBELLA 2000 becomes an extendable spirit level with a maximum length of 3100 mm.

- Made from anodised aluminium to prevent your hands or the surrounding area becoming dirty.
- The rail ends are equipped with protective fittings.

Ref. no.	Model	Length	Other	Qty/pack
407201	L 1200	1200 mm	-	1 pcs
407301	L 1500	1500 mm	-	1 pcs
407401	L 1800	1800 mm	-	1 pcs
407861	EVS 2000	-	End plug spirit level rail	1 pcs
407501	L 600+900	600 - 900	Extension rail set	1 pcs
407881	EFS 2000	-	End plug extension rail	1 pcs

* Model L600 + 900 is a set of extension rails.

Gradient Wedge Libella

With a gradient wedge fitted between the spirit level rail and your Libella 2000, you can check inclines/gradients.

- Made from ABS plastic, which makes the wedge both light and durable.
- Gradient is measured in millimetres per metre and the gradient wedge has 20 steps between 2 and 40 mm/m.
- Simply attaches to the spirit level rail using a strong steel wing nut.



Ref. no.	Model	Qty/pack
407601	F 2-40	1 pcs

MULTI-FUNCTION SPIRIT LEVEL – LIBELLA 2000.

LIBELLA 2000 is a short spirit level cast in aluminium with a smooth-finished contact surface. It is equipped with crush-proof block vials that have magnifying lenses and a luminescent reflector, which facilitates reading in environments that are not optimal. The radius of the vial is 1000 mm, giving a sensitivity

of 2 mm/m. Tolerance in normal position is ± 0.25 mm, upside down ± 0.75 mm/m. Adding spirit level rails and gradient wedges will increase the number of applications your LIBELLA 2000 can be used for.



1. When fitting door/window frames, LIBELLA 2000 can be used with a spirit level rail.
2. Using a spirit level rail and extensions, the maximum length is increased to 3100 mm.
3. In narrow spaces, use LIBELLA 2000 only.
4. You can check inclines using the gradient wedge.



Spirit Level CORDINAT

Spirit level made from a durable aluminium profile with graduations, four adjustable sliders and two tubular vials. Can be used for measuring, horizontal and vertical reading and distance marking. Ideal for applications such as hanging cupboards. Tolerance in normal position is ± 0.5 mm/m, upside down ± 0.75 mm/m.

- Transfer measured distances using the sliders.
- Position the measure distance on the wall and adjust using the vials.
- Easy centring using the zero point in the middle of the scale.
- The vials are highly resistant to ultraviolet light and fluctuations in temperature.
- The anti-static properties of the liquid means that the bubble is not affected by static electricity.

Ref. no.	Model	Length	Vials	Qty/pack
408604	CORDINAT	800 mm	2	10 pcs

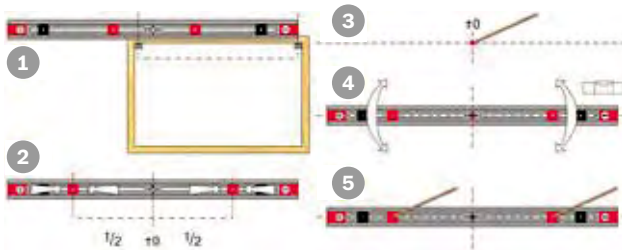

1. Measure the distance between the suspension points.
2. Set the measured distance using the sliders. Centre the measurement over the zero point.
3. Mark the zero point on the wall.
4. Adjust horizontal level using the vial.
5. Mark the measured distance on the wall.

Post Level JP

Post spirit level made from impact resistant ABS plastic, with three crush-proof tubular vials fitted to allow both horizontal and vertical measurement.

- The crush-proof vials have a radius of 180 mm, giving a sensitivity of 11 mm/m.
- The liquid in the vial is a low viscosity coloured oil mixture that gives the bubble optimal freedom of movement.
- Tolerance in normal position is ± 2.0 mm/m.

Ref. no.	Model	Dimensions (LxW)	Vials	Qty/pack
404403	JP	9x14 cm	3	5 pcs

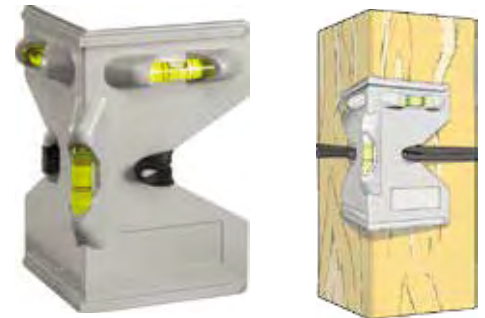

Inclinometers NAM, APN, NP

The inclinometer is made from a strong aluminium profile measuring 50x23 mm and weighing around 740 g/m. It has a 360° measurement range, split into four 90° arcs. The tool shows a gradient of 0-100%. Crush-proof block vials that are highly transparent and durable.

- The radius of the vial is 200 mm, giving a sensitivity of 10 mm/m.
- Tolerance in normal position is ± 0.5 mm/m = 0.03°.
- The liquid in the vial is a low viscosity coloured oil mixture that gives the bubble optimal freedom of movement.
- Highly resistant to ultraviolet light and temperature fluctuations.
- The anti-static properties of the liquid means that the bubble is not affected by static electricity.



Ref. no.	Model	Length	Vials	Magnets	Qty/pack
402101	NAM 13	130 mm	1	1	1 pcs
402201	NAM 50	500 mm	1	2	1 pcs
402301	APN 60	600 mm	1	-	1 pcs
402401*	NP 121	130x130 mm	1	-	1 pcs

*Model NP 121 is a protractor.

Inclinometers APK

Inclinometer with adjustable measurement piston, graduated up to an inclination of 10%. Made from strong aluminium profile measuring 50x24 mm and weighing 740 g/m. Crush-proof block vials that are highly transparent and durable. Horizontal vial with a magnification lens and luminescent reflector.

- The radius of the vial is 200 mm, giving a sensitivity of 10 mm/m.
- Tolerance in normal position is ± 0.5 mm/m.
- The liquid in the vial is a low viscosity coloured oil mixture that gives the bubble optimal freedom of movement.
- Highly resistant to ultraviolet light and temperature fluctuations.
- The anti-static properties of the liquid means that the bubble is not affected by static electricity.



Ref. no.	Model	Length	Vials	Qty/pack
402501	APK 100	1000 mm	1	1 pcs
402511	Adjuster pin	-	-	1 pcs
402521	Square SP	-	-	1 pcs
402531	Square	-	-	1 pcs

Line Spirit Level UZ

Small, neat line spirit level made from impact resistant plastic with a vial and hooks at both ends. Hang the level on a tensioned string to check the incline between two points.

- Made from ABS plastic, which makes the level both light and durable.
- The tubular vial is made from Plexiglas.
- The liquid in the vial is a low viscosity coloured oil mixture that gives the bubble optimal freedom of movement.



Ref. no.	Model	Length	Qty/pack
402804	UZ 8	80 mm	10 pcs

Hose Water Level S

Spirit level in two sections that you attach to either end of a hose, which is then filled with water. Suitable for checking the incline of larger surfaces.

- Made from acrylic glass, making them both light and durable.
- The bleed screws are made from brass in order to be highly resistant to corrosion.
- Fits two sizes of hose – 10 and 12 mm.
- The scale runs from 0-165 mm.



Ref. no.	Model	Scale	Hose dimensions	Qty/pack
402603	S 1012	0-165 mm	10 & 12 mm	5 pcs

Hose Water Level SP

Spirit level in two sections that you attach to either end of a hose, which is then filled with water. Suitable for checking the incline of larger surfaces.

- Made from ABS plastic, which makes them both light and durable.
- Fits two sizes of hose – 10 and 12 mm.
- The scale runs from 0-50-0 mm.



Ref. no.	Model	Scale	Hose dimensions	Qty/pack
402653	SP 20	0-50-0 mm	10 & 12 mm	3 pcs

Cross Spirit Level K

Spirit level in red impact resistant plastic with two perpendicular vials. Suitable for checking the incline of two dimensions at the same time.

- Made from ABS plastic, which makes the level both light and durable.
- The tubular vials are made from Plexiglas.

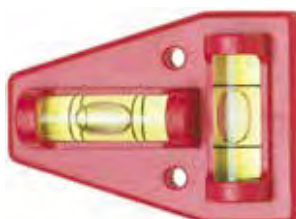

Ref. no.	Model	Vials	Qty/pack
402004	K 5	2	10 pcs

Mini Spirit Level R 102

Fitted in position with glue.



Ref. no.	Model	Dimensions (LxWxH)	Qty/pack
403501	R 102	95x50x15 mm	1 pcs

Block Vial NV 702

Fitted in position by two screws.



Ref. no.	Model	Dimensions (LxWxH)	Qty/pack
403801	NV 702	70x15x17 mm	1 pcs

Block Vial FV 40

Fitted in position with glue.

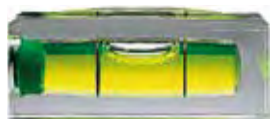

Ref. no.	Model	Dimensions (LxWxH)	Qty/pack
404201	FV 40	40x15x17 mm	1 pcs

Bull's Eye Level 701

Fitted in position with glue.



Ref. no.	Model	Dimensions	Qty/pack
404601	701	Ø12.8, H=9 mm	1 pcs

Glass Vial

Fitted in position with plaster.



Ref. no.	Model	Dimensions	Qty/pack
406523	9x50	Ø9, L=50 mm	5 pcs



Laser Spirit Level LWX

Spirit level with a laser. Made from strong aluminium profile measuring 59x26 mm and weighing 890 g/m. A good tool for marking horizontal and vertical lines, measuring and extending surfaces or installation at right angles. Horizontal vial with a magnification lens and luminescent reflector.

- Crush-proof block vials that are highly transparent and durable. The radius of the vial is 1000 mm, giving a sensitivity of 2 mm/m.
- Tolerance in normal position is ± 0.25 mm/m.
- Class 2 laser (EN 60825-1), wavelength 635 nm.
- Laser tolerance ± 0.15 mm/m with a working range of approximately 30 m.
- The vial liquid is highly resistant to ultraviolet light and fluctuations in temperature.

Ref. no.	Model	Length	Vials	Qty/pack
408011	LWX 60	600 mm	2	1 pcs



Digital Laser Spirit Level ELWX

Spirit level with a laser and digital unit. Made from strong aluminium profile measuring 59x26 mm and weighing 890 g/m. A good tool for marking horizontal and vertical lines, measuring and extending surfaces or installation at right angles. The digital unit also allows the marking of incline. Horizontal vial with a magnification lens and luminescent reflector.

- Crush-proof block vials that are highly transparent and durable. The radius of the vial is 1000 mm, giving a sensitivity of 2 mm/m.
- Tolerance in normal position is ± 0.25 mm/m.
- Class 2 laser (EN 60825-1), wavelength 635 nm. Laser tolerance ± 0.15 mm/m with a working range of approximately 30 m.
- The display shows tenths of degrees, percentages or mm/m. The figures are automatically displayed in the correct direction.
- Electronic unit tolerance in horizontal (0°) and vertical (90°) position is $\pm 0.1^\circ$, for other angles it is $\pm 0.2^\circ$.

Ref. no.	Model	Length	Vials	Qty/pack
408021	ELWX 60	600 mm	2	1 pcs

* Electronic unit tolerance in horizontal (0°) and vertical (90°) position is $\pm 0.1^\circ$. Tolerance for other angles is $\pm 0.2^\circ$.



Digital Spirit Level DM

Spirit level with digital unit, made from strong aluminium profile measuring 59x26 mm and weighing 890 g/m. A good tool for measuring or marking incline. The measurement area is 360°, split into four 90° zones. Shock-proof and water resistant, but should not be immersed in water. Horizontal vial with a magnification lens and luminescent reflector.

- Crush-proof block vials that are highly transparent and durable. The radius of the vials is 200 mm, giving a sensitivity of 10 mm/m.
- Tolerance in normal position is ± 0.3 mm/m, upside down ± 0.75 mm/m.
- The display shows tenths of degrees, percentages or mm/m. The figures are automatically displayed in the correct direction. Automatic shut-off after 6 minutes.
- Electronic unit tolerance in horizontal (0°) and vertical (90°) position is $\pm 0.1^\circ$, for other angles it is $\pm 0.2^\circ$.
- The vial liquid is highly resistant to ultraviolet light and fluctuations in temperature.

Ref. no.	Model	Length	Vials	Qty/pack
408401	DM 60	600 mm	2	1 pcs

* Electronic unit tolerance in horizontal (0°) and vertical (90°) position is $\pm 0.1^\circ$. Tolerance for other angles is $\pm 0.2^\circ$.

Protection Bag Levels

Protective case made from durable nylon for laser and digital spirit levels. Length 600 mm.

- Made from highly durable nylon.
- Wide and adjustable shoulder strap.
- Fits Laser Spirit Level LWX, Digital Laser Spirit Level ELWX and Digital Spirit Level DM.

Ref. no.	Model	Fits to	Qty/pack
408402	V 60	ELWX, LWX, DM	1 pcs



Prism

A prism that produces laser points at a 90° angle, model STM gives two laser points simultaneously, one straight ahead and one at a 90° angle. It can also be rotated a full turn. A magnetic attachment makes it easy to fit the prism to your laser spirit level.

- The prism allows your laser point to be turned through 360°.
- Made from stable and durable plastic.
- Fits Laser Spirit Level LWX and Digital Laser Spirit Level ELWX.

Ref. no.	Model	Fits to	Qty/pack
408135	VP	ELWX, LWX	1 pcs
408131	STM	ELWX, LWX	1 pcs



Laser Adapter

Laser adapter with 1/4" female and 5/8" male. The adapter enables the use of a tripod with a 1/4" connection with a laser that has a 5/8" thread.

Ref. no.	Model	Weight	Qty/pack
409090	LA-1	45 g	1 pcs



Laser Goggles LB

Goggles that make it easier for you to see and focus the laser point. Essential for working in areas where there is a lot of light that make it difficult to see the red point.

Ref. no.	Model	Qty/pack
408121	LB	1 pcs



LASERS TO BRIGHTEN

Type of laser

POINT LASER: The lens collects the radiated laser light and focuses into a single point.

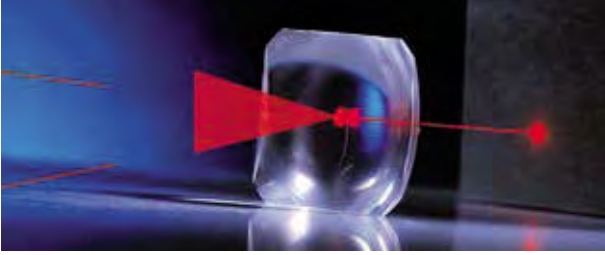

LINE LASER: Once a lens has collected the beams, they are passed through a tube lens, creating a laser line.

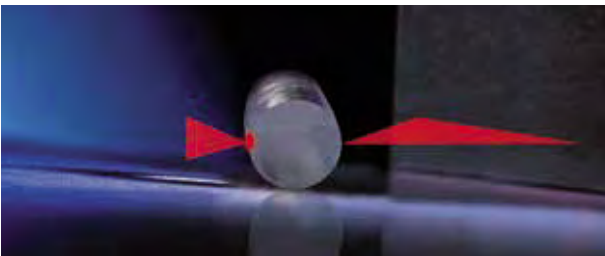

Lens quality

The lens has a decisive effect on quality as it focuses the radiated laser light to a narrow point. Two types of lens are used:

GLASS LENS: Produces a high quality beam, allowing high quality cutting. Its main advantage is that glass is heat resistant and retains its shape.

PLASTIC LENS: The quality of plastic lenses used by Hultafors is determined by means of a high precision extrusion process. The lenses can be used in temperatures up to 85 °C without losing their shape.

Laser classes from EN 60825-1

Class	Explanation
1	Laser radiation is not hazardous to vision.
1M	Laser radiation is not hazardous provided it is not focused using optics.
2	Laser radiation in the visible spectrum (400 nm to 700 nm), is not hazardous to vision if exposure lasts only a brief moment. The blink reflex will kick in before any damage is caused.
2M	Laser radiation may damage vision if it is focused using optics.
3R	Laser radiation is hazardous to vision.
3B	Laser radiation is hazardous to vision and may also damage skin.
4	Laser radiation is very hazardous to vision and will also damage skin. May cause fire and explosions.

VISIBLE LIGHT SPECTRUM

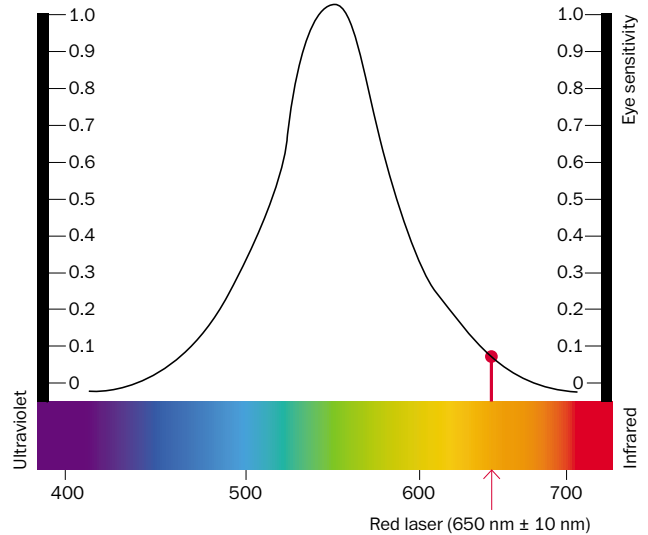

Wavelengths for light

The human eye is sensitive to light within the wavelength range 711 nm (red) to 389 nm (indigo). Shortwave light, otherwise known as ultraviolet (UV) light, is invisible to humans. Red laser light falls within the 670–630 nm range.

The shorter the wave, the sharper the laser light.

Diode intensity

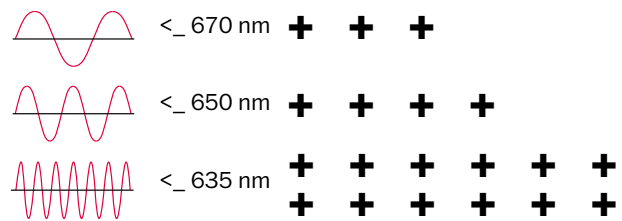

635 nm is 4 times clearer than 670 nm.

Laser classes

Generally speaking, laser classes fall into two groups – those that are compliant with European standard EN 601125-1 and those that are compliant with American standard FDA 1040.10:1.4.97.

A warning symbol and information must be shown on every laser product.

EN YOUR WORKDAY.

Levelling



LASER WITH AUTOMATIC LEVELLING:

» Magnetic pendulum system



Crossline Laser XL-2

Small, versatile and user-friendly cross-line laser. The laser is self-levelling, with 2 diodes for vertical and horizontal lines. The lines can be switched on separately or together to form a cross. There is an option to mechanically lock the pendulum to tilt the laser. The laser is equipped with a transportation lock that locks the pendulum when the laser is not in use. Simplifies jobs such as measuring out walls, kitchens or painting with two different colours. Tripod thread size is 5/8".

- Self-levelling range $\pm 5^\circ$.
- Tolerance: ± 1.0 mm/m.
- Laser class: 2M/EN 60825-1.
- Diode type: 2 x 635 nm.
- Detection area: $r=15$ m.

Ref. no.	Model	Weight	Height	Width	Depth	Qty/pack
409040	XL-2	400 g	120 mm	65 mm	105 mm	1 pcs



Floorcross Laser FXL

The floorcross laser has four laser lines at 90° to each other forming a cross in front of the unit. This enables you to lay tiles in four directions. The lines also continue behind the laser, which means that you can lay tiles in the entire space with a single measurement. The laser has adjustable feet for work on uneven surfaces, plus a 5 mm spacer foot, which makes it possible to lay tiles underneath the unit. Makes laying tiles easy.

- Tolerance: ± 0.3 mm/m.
- Laser class: 2/EN 60825-1.
- Diode type: 4 x 635 nm.
- Detection area: $r=10$ m per line.

Ref. no.	Model	Weight	Height	Width	Depth	Qty/pack
409030	FXL	650 g	55 mm	235 mm	151 mm	1 pcs



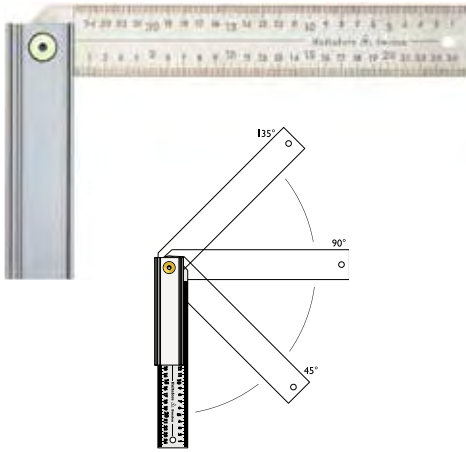

Adjustable Square QUATTRO

Square with millimetre graduations that can be set to three positions: 45°, 90° and 135°. The stock and blade can also be folded together, making it easy to store and keep in the pocket of your work trousers.

- The stock is made from anodised aluminium.
- The blade is 45 mm wide and made from stainless steel.
- Graduations are deep etched and highly resistant to wear.

Ref. no.	Model	Blade length	Tolerance	Qty/pack
253103	Quattro 25	25 cm	±0,06°	5 pcs



Square Professional

Square with aluminium stock and millimetre graduations on the upper and lower edges of the blade.

- The blade is made from stainless steel, measuring 1.5x45 mm.
- The stock is made from anodised aluminium, with an 18 mm wide milled working surface.
- Graduations are deep etched and highly resistant to wear.

Ref. no.	Model	Blade length	Tolerance	Qty/pack
260003	V 20 P	20 cm	±0,03°	5 pcs
260103	V 25 P	25 cm	±0,03°	5 pcs
260203	V 30 P	30 cm	±0,03°	5 pcs



Square Semi-Professional

Square with fibreglass-reinforced ABS plastic stock and millimetre graduations on the upper and lower edges of the blade.

- The blade is made from stainless steel, measuring 1.0x45 mm.
- Fibreglass-framed ABS plastic stock, with an 18 mm wide working surface.
- Graduations are deep etched and highly resistant to wear.

Ref. no.	Model	Blade length	Tolerance	Qty/pack
310003	V 20 S	20 cm	±0,06°	5 pcs
310103	V 25 S	25 cm	±0,06°	5 pcs
310203	V 30 S	30 cm	±0,06°	5 pcs



Carpenter's Square TMV

Carpenter's square with epoxy-lacquered steel stock and millimetre graduations on the upper and lower edges of the blade.

- Yellow epoxy-lacquered steel square.
- Tolerance ±1.0 mm/m.
- Screen printed mm graduations.

Ref. no.	Model	Blade length	Tolerance	Qty/pack
251003	TMV 60	60 cm	±1,0 mm/m	5 pcs
251103	TMV 80	80 cm	±1,0 mm/m	5 pcs
251203	TMV 100	100 cm	±1,0 mm/m	5 pcs

Plaster Square PS

Adjustable plaster square with millimeter and degree graduations that can be set in four fixed positions. The stock and blade can be folded together, making it easy to store and transport and also be switch between right and left position.

- The foldable function makes storage and transport easier.
- 4 angles with fixed positions (22.5°, 45°, 67.5°, 90°).
- Additional 21 angles marked on the scale.
- Stock and blade in anodized aluminium.



Ref. no.	Model	Length	Weight	Qty/pack
253501	PS 120	1200 mm	1150 g	2 pcs

Bevel Square SMV

Bevel square with stainless steel blade and aluminium stock with milled working surfaces, for copying and transferring angles to workpieces.

- Stainless steel blade.
- Aluminium stock with milled working surfaces.
- Screw for locking the blade is located in the end of the stock for improved accessibility.

Ref. no.	Model	Blade length	Qty/pack
256003	SMV 20	20 cm	5 pcs



Combi Square

The combi square is used to measure existing angles or to transfer angles from a point of measurement to a workpiece.

- Made from anodised aluminium for increased corrosion resistance.
- Alpha x read on the left side of the scale, Beta x on the right.
- Can be used to read angles between 20° and 160°.

Ref. no.	Model	Blade length	Qty/pack
252003	Combi	17 cm	5 pcs

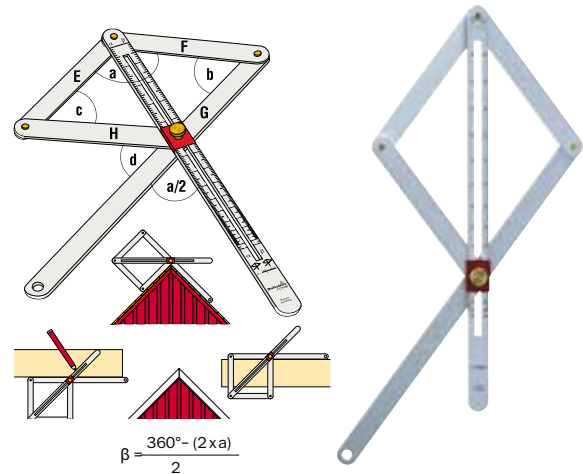

Mitre Square GV

Automatically produces the correct angle when cutting mitres without having to perform any calculations. When the tool is steplessly turned to the desired angle, the indicator flag divides the angle by two.

- The guide is made from fibreglass-reinforced nylon, with an indicator flag of electrogalvanised metal.
- Automatically produces the correct angle when cutting mitres.
- Can be used for both internal and external angles.

Ref. no.	Model	Qty/pack
254003	GV	4 pcs

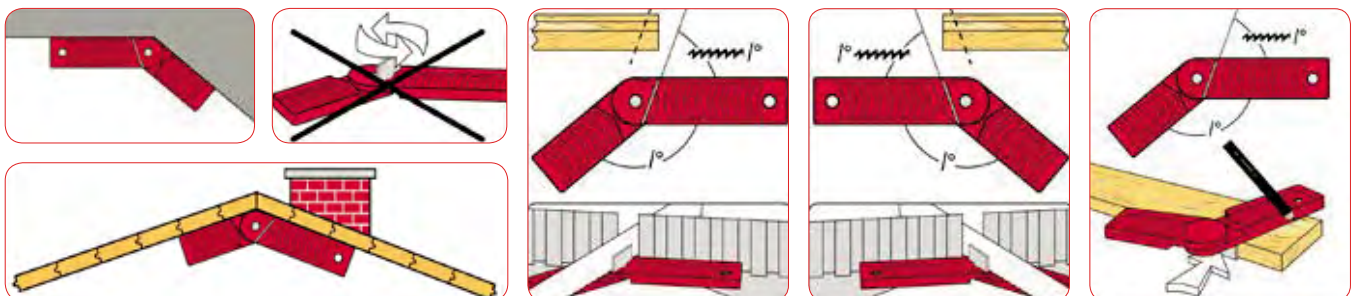
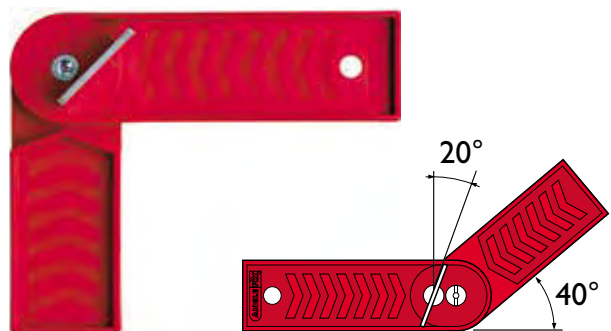

Chalk with quality. Our chalkline chalk is finely milled so that it effectively attaches to the line. It is pigment-rich, which produces a clear and long-lasting line.

Straight lines. A chalkline is a smart tool for when you want to mark out straight lines, both indoors and out.



Different colours. Chalk is available in a number of different colours for use on various materials and in different environments. For example, our ultramarine chalk is best able to withstand wind and rain, whilst our white chalk is the only one which you can paint over.

Durable lines. In our chalklines, we use a braided line made from cotton and polyester. The cotton absorbs the chalk, the polyester provides the strength and the braiding ensures that the line does not tangle.

Chalk line AL

Chalk line in cast powder coated aluminium housing with sliding filler cover. The line is braided cotton/polyester.

- The cotton absorbs the chalk, the polyester provides the strength.
- The braiding ensures that the line does not tangle.
- The line is 1 mm in diameter and has a rupture limit of 16 kg. Also available as a spare part.
- Holds 80 g of chalk.

Ref. no.	Model	Length	Weight	Qty/pack
652153	AL 30	30 m	140 g	6 pcs
652143*	RAL 30	30 m	60 g	6 pcs

*Model RAL 30 is a spare line.

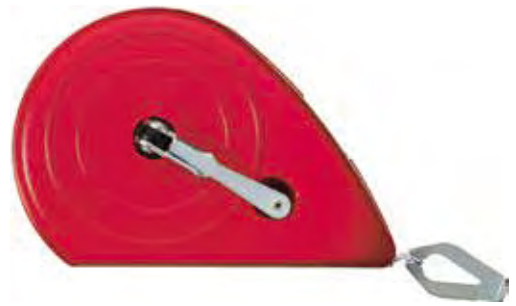

Chalkline CLP

Chalk line with 30 m line, metal crank and quick gear function 3:1. The house is manufactured in ABS plastic with a big opening for refilling and a cap with bayonet joint. Contains 100 g of chalk. The line is braided cotton/polyester – with high absorbing chalk capacity – considerable increased numbers of distinct lines, up to 10 lines. Crank with ergonomic release button and knob. Crank can be locked in open and closed position. The cap is secured by the hook, no line hanging loose. Secure strap function.

- Overload protection reducing the risk for damaging the gear mechanism and the line to break.
- Release function in open and closed crank position. (Crank will not spin when pulling out line).
- Braided line with high absorbing chalk capacity - considerable increased numbers of distinct lines.
- Gear function 3:1, rewinds the line 3 times faster.
- The cap is divisible, makes it simple to replace the line.

Ref. no.	Model	Length	Weight	Qty/pack
652113	CLP 30	30 m	205 g	2 pcs
652133*	RCL 30	30 m	65 g	1 pcs

*Model RCL 30 is a spare line.

Registered Community Design No. 001230320-1/2
Patent application filed EP 10173276.6, EP 10173271.7, EP 10173290.7



Chalk line RL

Large chalk line with extra strong cord that is ideal for demanding outdoor work. The housing is made from hard and durable polystyrene plastic. Chalk is filled via a bottle attached directly to the chalkline. The bottle is not included.

- The cotton absorbs the chalk, the polyester provides the strength.
- The braiding ensures that the line does not tangle.
- The line is 3 mm in diameter and has a rupture limit of 55 kg. The line is available as a spare part.
- Holds 700 g of chalk, including a standard bottle.

Ref. no.	Model	Length	Weight	Qty/pack
652181	RL 50	50 m	620 g	1 pcs
652191*	RRL 50	50 m	250 g	1 pcs

*Model RRL 50 is a spare line.

*The bottle is not included.



Chalkline HHSK

Chalk line set including 100 g blue chalk. Chalk line with 30 m line, manufactured of polystyrene with removable filler cap. The line is of twisted cotton/polyester, 1 mm in diameter.

- Holds 80 g of chalk.
- Comes with 100 g blue chalk.

Ref. no.	Model	Length	Weight	Qty/pack
660103	HHSK 30	30 m	80 g	12 pcs





Chalkline Chalk ULTRABLUE

This ultrablue chalk is optimised for outdoor use. It provides a strong, clear line that is extremely resistant to the effects of wind and rain.

- Pigment-rich, producing clear and long-lasting lines.
- The chalk is finely milled and effectively attaches to the cord.
- Contains dolomite and ultramarine.

Ref. no.	Model	Weight	Qty/pack
652633	ULTRA BLUE 400	400 g	6 pcs
652641	ULTRA BLUE 1000	1000 g	1 pcs



Chalkline Chalk BLUE

This blue chalk is the most widely used chalk. It can be used for both indoor and outdoor work.

- Pigment-rich, producing clear and long-lasting lines.
- The chalk is finely milled and effectively attaches to the cord.
- Contains dolomite and ultramarine.

Ref. no.	Model	Weight	Qty/pack
652523	BLUE 100	100 g	6 pcs
652533	BLUE 360	360 g	6 pcs



Chalkline Chalk YELLOW

This yellow chalk is particularly suited to use on dark surfaces. It can be used for both indoor and outdoor work.

- Pigment-rich, producing clear and long-lasting lines.
- The chalk is finely milled and effectively attaches to the cord.
- Contains dolomite and iron oxide.

Ref. no.	Model	Weight	Qty/pack
652333	YELLOW 360	360 g	6 pcs



Chalkline Chalk WHITE

This white chalk is the only chalk that can be covered over with paint. Used mostly for indoor work.

- Pigment-rich, producing clear and long-lasting lines.
- The chalk is finely milled and effectively attaches to the cord.
- Contains dolomite.

Ref. no.	Model	Weight	Qty/pack
652233	WHITE 360	360 g	6 pcs



Chalkline Chalk RED

This red chalk is an all-round chalk suitable for both indoor and outdoor work.

- Pigment-rich, producing clear and long-lasting lines.
- The chalk is finely milled and effectively attaches to the cord.
- Contains dolomite and iron oxide.

Ref. no.	Model	Weight	Qty/pack
652423	RED 100	100 g	6 pcs
652433	RED 360	360 g	6 pcs



Chalkline Chalk H.V GREEN

This neon green chalk produces very clear lines. Can be used for both indoor and outdoor work.

- Produces strong, clear lines.
- The chalk is finely milled and effectively attaches to the cord.
- Pigment-rich, producing clear and long-lasting lines.

Ref. no.	Model	Weight	Qty/pack
652733	H.V GREEN 200	200 g	6 pcs



Chalkline Chalk H.V ORANGE

This neon orange chalk produces very clear lines. Can be used for both indoor and outdoor work.

- Produces strong, clear lines.
- The chalk is finely milled and effectively attaches to the cord.
- Pigment-rich, producing clear and long-lasting lines.

Ref. no.	Model	Weight	Qty/pack
652833	H.V ORANGE 200	200 g	6 pcs



Carpenter's Pencil SNP

Carpenter's pencil made from linden wood with a medium-hard lead (HB), for optimal function on wood, plaster and other soft materials.

- Easy to sharpen as linden is a softwood with few transversal fibres.
- Medium-hard lead (HB) for optimal function on wood, plaster and other soft materials.
- Supplied in display box containing 200 pencils.

Ref. no.	Model	Length	Hardness	Qty/pack
650207	SNP 18 RED	180 mm	HB	200 pcs
650707	SNP 18 BLACK	180 mm	HB	200 pcs
650407	SNP 24 BLUE	240 mm	HB	200 pcs
650807	SNP 24 BLUE OVAL	240 mm	HB	200 pcs



Concrete Pencil BEP

Concrete pencil made from linden wood with a very hard lead. Ideal if you need to mark hard surfaces such as stone and concrete.

- Easy to sharpen as linden is a softwood with few transversal fibres.
- Very hard lead (10 H) for optimal function on hard surfaces such as stone and concrete.
- Supplied in a practical display box.

Ref. no.	Model	Length	Hardness	Qty/pack
650307	BEP 30 GREEN	300 mm	10 H	200 pcs



Workshop Pencils VEP

Available in two different hardnesses, medium (H) and hard (2H).

- Supplied in a cardboard box of 12.

Ref. no.	Model	Length	Hardness	Qty/pack
650507	VEP 175 H	175 mm	H	144 (12) pcs
650607	VEP 175 2H	175 mm	2H	144 (12) pcs



Pencil Extension

Made from ABS plastic, allowing you to use the full length of the pencil.

- Fits both carpenter's and concrete pencils.
- Supplied in packs of 2.

Ref. no.	Model	Length	Qty/pack
650254	PEFO 150	150 mm	10 (2) pcs



LEVELLING RODS

Levelling rods made of wood. Available in several models and sizes.
Used to measure ground levels during building and road construction.

Length rounded up to the nearest metre	1 m	2 m	3 m	4 m
Tolerance (mm)	±1.0	±1.4	±1.8	±2.2



N 2 = Natural with mm scale.



RG 6 = Yellow reflector with feet scale in tenths.



RG 1 = Yellow reflector with cm scale.



Levelling Rod 701

Levelling rod made of wood, length 2 m and 1 section, width 35 mm.

- Yellow reflector with cm scale on one side.
- Natural with mm scale on the other side.
- Solid wood core and brass fittings.

Ref. no.	Model	Length	Parts	Width	Qty/pack
450341	701 RG1 N2	2 m	1	35 mm	1 pcs



Levelling Rod 702

Levelling rod made of wood, length 2.5 m and 2 sections, width 35 mm.

- Yellow reflector with cm scale on one side.
- Natural with mm scale on the other side.
- Solid wood core and brass fittings.

Ref. no.	Model	Length	Parts	Width	Qty/pack
450371	702 RG1 N2	2,5 m	2	35 mm	1 pcs



Levelling Rod 704

Levelling rod made of wood, length 4 m and 4 sections, width 35 mm.

- Yellow reflector with cm scale on one side.
- Model N2 natural with mm scale on the other side.
- Model RG6 has a yellow reflector with feet scale in tenths on the other side.
- Solid wood core and brass fittings.

Ref. no.	Model	Length	Parts	Width	Qty/pack
450101	704 RG1 N2	4 m	4	35 mm	1 pcs
450111*	704 RG1 N2L	4 m	4	35 mm	1 pcs
450201	704 RG1 RG6	4 m	4	35 mm	1 pcs

Model N2L is equipped with level.



Extension Rod 710

Levelling rod extension made of wood.

- Yellow reflector with cm scale on one side.
- Solid wood core and brass fittings.

Ref. no.	Model	Length	Parts	Width	Qty/pack
450401	710 RG1	2 m	2	36 mm	1 pcs



Levelling Rod Mini

Foldable levelling rod made of wood. Designed as a folding rule which makes it easy to fold and carry.

- Yellow reflector with cm scale on one side.
- Natural with mm scale on the other side.
- Brass end fittings.

Ref. no.	Model	Length	Parts	Width	Qty/pack
450704	742 RG1 N2	2 m	6	23 mm	10 pcs
450904	743 RG1 N2	3 m	6	23 mm	10 pcs

Bench Rule

With metric graduation.



Ref. no.	Model	Length	Width/Thickness	Qty/pack
550004	SLM 50	500 mm	25/5 mm	10 pcs
550104	SLM 100	1000 mm	25/5 mm	10 pcs

Counter Rule

With metric graduation.



Ref. no.	Model	Length	Graduation	Qty/pack
550201	BUM 50	650 mm	500 mm	1 pcs
550301	BUM 100	1145 mm	1000 mm	1 pcs

Glasscutter's Rule

With metric graduation.



Ref. no.	Model	Length	Graduation	Qty/pack
550411	GLM 100	1060 mm	1000 mm	1 pcs
550501*	GLM handle	-	-	1 pcs

*Handle is available as a spare part.

Personal Rule

With metric graduation.



Ref. no.	Model	Length	Width/Thickness	Qty/pack
552801	PEM 136	1360 mm	40/20 mm	1 pcs
552901*	PEM slider	-	-	1 pcs

*Slider is available as spare part.

Wood Rule

With metric graduation.



Ref. no.	Model	Length	Parts	Width/Thickness	Qty/pack
551601	VEM 300	3000 mm	3	35/15 mm	1 pcs

Plank Rule

Shrinkage scale on reverse.



Ref. no.	Model	Length	Parts	Width/Thickness	Qty/pack
551204	PLM 33	330 mm	2	17/6 mm	10 pcs

Steel Ruler

Steel scale in tempered stainless steel, with matt chromeplated surface for anti-glare reading. Graduated in millimetres along the upper edge and half-millimetres along the lower edge. The reverse side is blank.

- Made from tempered stainless steel for extra durability.
- The surface is matt chrome-plated for anti-glare and more accurate reading.
- Graduated in millimetres along the upper edge, half-millimetres along the lower edge and with decimetre figures in red.
- Tolerance ± 0.3 mm/m.

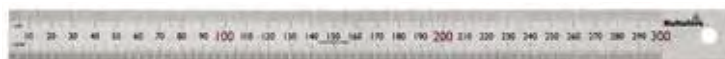

Ref. no.	Model	Length	Width/Thickness	Qty/pack
554003	STL 150	150 mm	14.7/0.6 mm	5 pcs
554103	STL 300	300 mm	23.7/1.0 mm	5 pcs
554203	STL 600	600 mm	28.5/1.2 mm	5 pcs
554303	STL 1000	1000 mm	35.0/1.5 mm	5 pcs



Optimal function. The striking surface of our carpenter's hammers have the right angle and shape. The claw is both thin and strong. The opening is angled so that it provides a good grip and leaves no marks. It also has rounded edges, preventing injury to you and damage to your clothes.

Vibration damping. Damaging vibrations generated in the hammer head can be transferred to the shaft and your hand. This vibration energy can be dampened by breaking and reflecting the shockwave before it reaches the back end of the hammer.

Shafts in a variety of materials.

Our shafts are made from hickory, steel or fibreglass. The steel shafts all have a ribbed rubber handle to provide the best possible grip. For better durability and service life, choose a fibreglass shaft.

Choose the right shaft! An ergonomic shaft is designed so that size, shape, pattern and material combine to provide the right level of friction and a relaxed grip. Choose the right shaft size and you'll reduce the strain you put on your muscles and tendons.

Light is right! A lightweight hammer can be swung more quickly than a heavier tool and places less stress on the body whilst being equally effective. If you want to spare your body and, at the same time, minimise the risk of injury, choose the lightest hammer possible based on the criteria for your job.

THE NEXT GENERATION OF HAMMER.

Pick up one of our claw hammers and you'll feel it at once: it just feels right in your hand. Once you've worked with it for a while, we promise that you'll see what makes it stand out from the crowd. Lithe, yet powerful and perfectly designed for your job. The ergonomic shaft is available in a variety of sizes, allowing you to choose a hammer that gives you a relaxed grip, which places less strain on the body. You also benefit from vibration damping, which you will notice each time you make a strike. You'll also notice the difference in the long term, as the technology reduces the risk of stress-related injuries.

The fact that our TC and TR claw hammers have been a hit shouldn't be a surprise. They have been developed in conjunction with professional craftsmen, who have imposed stringent requirements on everything from function and weight to appearance. Working together with our ergonomists, they tested and evaluated our prototypes, and we made changes, polished and re-tested them until all parties were completely satisfied. The result of all this is what you see here: a generation of effective claw hammers that are designed specifically for the way you work – and reduce the stress placed on your body. On site, every day.

Claw Hammer TC/TR

An ergonomically designed hammer, forged in one piece for increased durability with a vibration damping urethane plug. Thin, strong claw that affords easy access without leaving marks. The claw opening and angle give the best possible grip on the nail. Ergonomically designed handle with clear end stop and a secure grip.

- Vibration damping urethane plug.
- Right angle and shape of striking face.
- Steel shaft with I-profile for increased durability.
- Thin, strong claw that affords easy access without leaving marks. In addition, the claw is rounded to prevent it tearing your trousers.
- The TR has a straight claw for better access and a longer shaft for more power for more demanding applications.
- Ergonomically designed handle with a clear end stop. TC is available in two sizes, Large and X-Large.



Ref. no.	Model	Weight including shaft	Shaft	Qty/pack
820110	TC 16 L	720 g	Large	2 pcs
820120	TC 16 XL	720 g	X-Large	2 pcs
820130	TC 20 L	795 g	Large	2 pcs
820140	TC 20 XL	795 g	X-Large	2 pcs

Registered Community Design No. 000843404-1/4

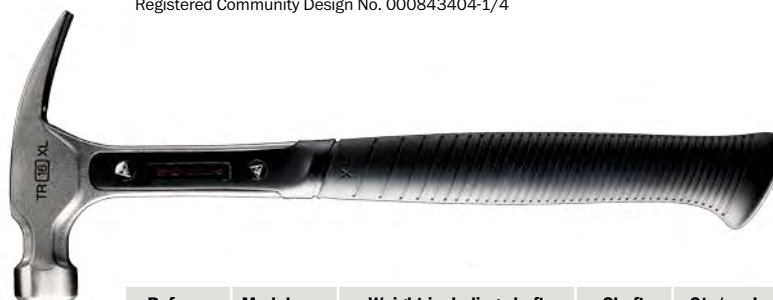

Ref. no.	Model	Weight including shaft	Shaft	Qty/pack
820220	TR 16 XL	740 g	X-Large	2 pcs
820240	TR 20 XL	810 g	X-Large	2 pcs

Registered Community Design No. 000843404-1/4

Claw Hammer TS

Ergonomically designed hammer with a thin, strong claw that affords easy access without leaving marks. The claw opening and angle give the best possible grip on the nail.

- Right angle and shape of striking face for optimal working conditions.
- The claw opening and angle give the best possible grip on the nail.
- Thin, strong claw affords easy access without leaving marks.
- The claw is rounded to prevent it tearing your work trousers.
- Ergonomically designed and ribbed handle for optimal grip.



Ref. no.	Model	Weight including shaft	Shaft	Spare shaft	Qty/pack
820006	TS 16	720 g	S	-	2 pcs
820008	TS 20	800 g	S	-	2 pcs

Claw Hammer HSH

Claw hammer with steel tube shaft.

- 2-component handle for efficient grip.



Ref. no.	Model	Weight including shaft	Shaft	Spare shaft	Qty/pack
866002	HSH 16	720 g	S	-	2 pcs

Claw Hammer KP

A powerful carpenter's hammer with spike and square striking face. The shaft is fitted to the head using steel rails.

- The hammer head is hand-forged with a tempered striking face and claw.
- The wooden shaft is available as a spare.
- Steel rails for fitting the shaft are available as spares.



Ref. no.	Model	Weight including shaft	Shaft	Spare shaft	Qty/pack
820066	KP 650	800 g	H	827231	2 pcs
820065	KP 750	900 g	H	827231	2 pcs
820070*	KPS rails	-	-	-	1 pcs

*Spares for re-shafting hammer.

Claw Hammer EL

A versatile hammer with a U-shaped striking face. The U-shape makes it possible to work close to ceilings and corners without leaving marks on surrounding surfaces. Ideal for working in narrow spaces.

- The U-shaped striking face makes it possible to drive nails into surfaces close to ceilings and corners.
- The straight claw makes it easy to get at and remove nails and clamps in narrow spaces.
- Ergonomically designed handle affords good grip along the entire shaft, regardless of power or precision required.



Ref. no.	Model	Weight including shaft	Shaft	Spare shaft	Qty/pack
820040	EL	550 g	S	-	2 pcs

Joiner's Hammer SH

A small hammer with a square face and cross pein and a hickory shaft.

- The hammer head is hand-forged with a tempered pein and striking face.
- The forging conforms to the requirements of DIN 1041.
- The wooden shaft is available as a spare.



Ref. no.	Model	Weight including shaft	Shaft	Spare shaft	Qty/pack
822001	SH 200	250 g	H	827070	2 pcs
822002	SH 250	325 g	H	827071	2 pcs
822003	SH 400	500 g	H	827071	2 pcs

G = Fibreglass H = Hickory S = Steel

Nail Puller ATLE

A versatile and easy-to-use nail puller. Despite its small size, it can easily pull out a 5-inch nail, even when the head is off or buried deep in the wood.

- You use it together with your carpenter's hammer and pull using the claw.
- Made from red painted steel.

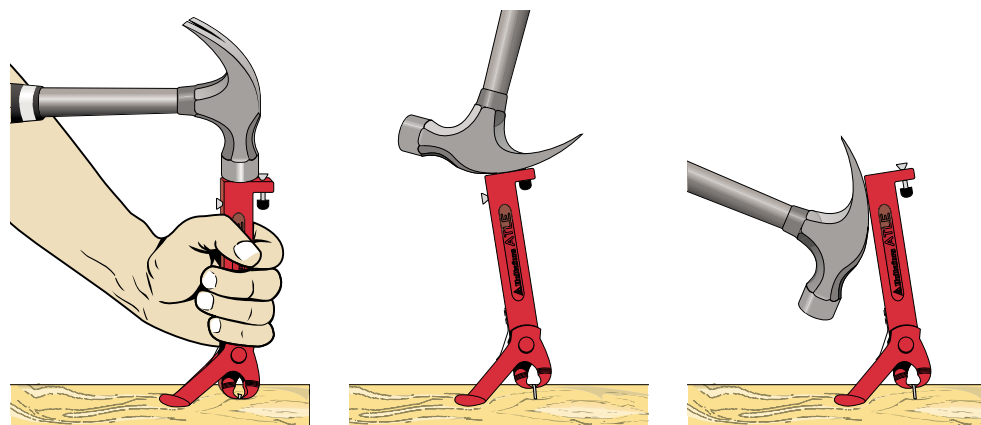

Ref. no.	Model	Weight	Qty/pack
820030	Atle	600 g	5 pcs

Combi Hammer T-Block

Ergonomically designed hammer that increases precision and reduces tiredness. The head is filled with steel balls that dampen shock and reduce recoil. Counterweights in the shaft inhibit rotation.

- Ergonomically designed handle that affords good grip along the entire shaft.
- The head is filled with steel ball bearings that dampen vibrations and reduce recoil.
- Counterweights in the shaft inhibit rotation and improve balance and hammer control.
- Replaceable nylon striking face available as a spare.



Ref. no.	Model	Weight including shaft	Shaft	Spare strikers	Qty/pack
821259	C 250 S	550 g	S	821266	2 pcs
821262	C 375 M	650 g	S	821267	2 pcs
821264	C 600 L	900 g	S	821268	2 pcs

Patent No. SE 9502717-3

Pein Hammer T-Block

Ergonomically designed hammer that increases precision and reduces tiredness. The head is filled with steel balls that dampen shock and reduce recoil. Counterweights in the shaft inhibit rotation.

- Ergonomically designed handle that affords good grip along the entire shaft.
- The head is filled with steel ball bearings that dampen vibrations and reduce recoil.
- Counterweights in the shaft inhibit rotation and improve balance and hammer control.



Ref. no.	Model	Weight including shaft	Shaft	Qty/pack
821159	P 250 S	550 g	S	2 pcs
821162	P 375 M	650 g	S	2 pcs
821164	P 600 L	900 g	S	2 pcs

Patent No. SE 9502717-3

Ball Pein Hammer T-Block

Ergonomically designed hammer that increases precision and reduces tiredness. The head is filled with steel balls that dampen shock and reduce recoil. Counterweights in the shaft inhibit rotation.

- Ergonomically designed handle that affords good grip along the entire shaft.
- The head is filled with steel bearings that dampen vibrations and reduce recoil.
- Counterweights in the shaft inhibit rotation and improve balance and hammer control.



Ref. no.	Model	Weight including shaft	Shaft	Qty/pack
821059	K 250 S	550 g	S	2 pcs
821062	K 375 M	650 g	S	2 pcs
821064	K 600 L	900 g	S	2 pcs

Patent No. SE 9502717-3

S = Steel



Pein Hammer AB

Blasted and clear-lacquered ironwork, with tempered striking face and extended pein. Hickory shaft.

- The hammer head is hand-forged with a tempered pein and striking face.
- The wooden shaft is available as a spare.

Ref. no.	Model	Weight including shaft	Shaft	Spare shaft	Qty/pack
821003	AB 150	200 g	H	827001	2 pcs
821004	AB 200	300 g	H	827002	2 pcs
821005	AB 300	400 g	H	827002	2 pcs
821006	AB 400	500 g	H	827004	2 pcs
821007	AB 600	700 g	H	827004	2 pcs



Ball Pein Hammer XK

Blasted and clear-lacquered ironwork, with tempered striking face and polished ball. Hickory shaft.

- The hammer head is hand-forged with a tempered striking face and polished ball.
- The wooden shaft is available as a spare.

Ref. no.	Model	Weight including shaft	Shaft	Spare shaft	Qty/pack
821051	XK 150	200 g	H	827001	2 pcs
821052	XK 200	300 g	H	827002	2 pcs
821053	XK 300	400 g	H	827002	2 pcs
821054	XK 400	500 g	H	827004	2 pcs
821055	XK 500	600 g	H	827004	2 pcs



Blacksmith's Hammer Z

Blasted and clear-lacquered ironwork, with tempered pein and striking face. Hickory shaft. Smith's Hammer ZR 1000 has a steel shaft with a rubber grip.

- The hammer head is hand-forged with a tempered pein and striking face.
- The wooden shaft is available as a spare.

Ref. no.	Model	Weight including shaft	Shaft	Spare shaft	Qty/pack
822162	ZR 1000	1375 g	S	-	2 pcs
822152	Z 900	1000 g	H	827206	2 pcs
822155	Z 1200	1400 g	H	827208	2 pcs
822156	Z 1500	1700 g	H	827208	2 pcs
822157	Z 2000	2300 g	H	827208	2 pcs



Club Hammer ME

Blasted and clear-lacquered ironwork, with tempered and plane-ground striking face on both sides. Hickory shaft. Club Hammer MER 1200 has a steel shaft with a rubber grip.

- The hammer head is hand-forged with tempered and plane-ground striking faces.
- The wooden shaft is available as a spare.

Ref. no.	Model	Weight including shaft	Shaft	Spare shaft	Qty/pack
822112	MER 1200	1700 g	S	-	2 pcs
822101	ME 1000	1150 g	H	827222	2 pcs
822102	ME 1200	1350 g	H	827222	2 pcs
822103	ME 1500	1650 g	H	827222	2 pcs

H = Hickory S = Steel

Club Hammer MH

Blasted and clear-lacquered ironwork, with tempered and plane-ground striking face on both sides. Hickory shaft. Club Hammer MHR 1250 has a steel shaft with a rubber grip.

- The hammer head is hand-forged with tempered and plane-ground striking faces.
- The wooden shaft is available as a spare.



Ref. no.	Model	Weight including shaft	Shaft	Spare shaft	Qty/pack
843300	MH 1000	1170 g	H	842091	2 pcs
843301	MH 1500	1700 g	H	842091	2 pcs
843302	MH 2000	2250 g	H	842092	2 pcs

Club Hammer HHMH

Club hammer with black painted ironwork, with tempered and plane-ground striking face on both sides.

- Steel tube shaft with rubber handle.



Ref. no.	Model	Weight including shaft	Shaft	Spare shaft	Qty/pack
866502	HHMH 1250	1200 g	S	-	2 pcs

Blacksmith's Hammer SMH

Blasted and clear-lacquered ironwork, with tempered pein and striking face. Hickory shaft.

- The hammer head is hand-forged with a tempered pein and striking face.
- The wooden shaft is available as a spare.



Ref. no.	Model	Weight including shaft	Shaft	Spare shaft	Qty/pack
843100	SMH 1000	1150 g	H	842073	2 pcs
843101	SMH 1500	1650 g	H	842073	2 pcs
843102	SMH 2000	2150 g	H	842074	2 pcs

Bench Hammer B

Blasted and clear-lacquered ironwork, with tempered pein and striking face. Hickory shaft.

- The hammer head is hand-forged with a tempered pein and striking face.
- The wooden shaft is available as a spare.



Ref. no.	Model	Weight including shaft	Shaft	Spare shaft	Qty/pack
822050	B 200	300 g	H	827085	2 pcs
822051	B 300	400 g	H	827086	2 pcs
822052	B 400	500 g	H	827086	2 pcs

Tinsmith's Hammer PR

Blasted and clear-lacquered ironwork, with tempered pein and striking face. Ergonomically designed and ribbed handle for optimal grip.

- The hammer head is hand-forged with a tempered pein and striking face.
- The shaft is made from steel and has a ribbed rubber handle that affords good grip.



Ref. no.	Model	Weight including shaft	Shaft	Spare shaft	Qty/pack
822215	PR 300 M	525 g	S	-	2 pcs
822216	PR 400 M	635 g	S	-	2 pcs

H = Hickory S = Steel

Tile Hammer PL

Blasted and clear-lacquered ironwork, with tempered pein and square striking face. Hickory shaft.

- The hammer head is hand-forged with a tempered pein and striking face.
- The wooden shaft is available as a spare.

Ref. no.	Model	Weight including shaft	Shaft	Spare shaft	Qty/pack
822220	PL 100	150 g	H	-	2 pcs



Glazier Hammer GMH

Blasted and clear-lacquered ironwork, with a tempered, round striking face. Hickory shaft.

- The hammer head is hand-forged with a tempered pein and striking face.
- The wooden shaft is available as a spare.

Ref. no.	Model	Weight including shaft	Shaft	Spare shaft	Qty/pack
822290	GMH 150	200 g	H	827002	2 pcs



Welder's Pick

Small and versatile pick made from steel.

Ref. no.	Model	Weight including shaft	Shaft	Spare shaft	Qty/pack
828231	SV 150	280 g	S	-	10 pcs



Bricklayer's Hammer M

Blasted and clear-lacquered ironwork, with tempered square striking face and wide, ground chisel. Notch for pulling nails and a hickory shaft.

- The hammer head is hand-forged with a tempered chisel and striking face.
- The wooden shaft is available as a spare.

Ref. no.	Model	Weight including shaft	Shaft	Spare shaft	Qty/pack
822241	M 500	680 g	H	827261	2 pcs
822251	M 600	820 g	H	827261	2 pcs



Bricklayer's Hammer TB

An ergonomically designed hammer, forged in one piece for increased durability with a vibration damping urethane plug. Tempered square striking face and a strong ground chisel with a notch for pulling out nails.

- Right angle and shape of chisel for safe splitting of bricks.
- Steel shaft with I-beam for increased durability.
- Vibration damping urethane plug.
- Handle with a distinct end stop to ensure a secure grip.

Ref. no.	Model	Weight including shaft	Shaft	Spare shaft	Qty/pack
822281	TB 600	900 g	S	-	1 pcs



Bricklayer's Hammer MR

Blasted and clear-lacquered ironwork, with tempered square striking face and ground chisel. Steel shaft with ergonomically designed and ribbed handle for optimal grip.

- The hammer head is hand-forged with a tempered chisel and striking face.
- The shaft is made from steel and has a ribbed rubber handle that affords good grip.

Ref. no.	Model	Weight including shaft	Shaft	Spare shaft	Qty/pack
822261	MR 500	820 g	S	-	2 pcs



H = Hickory S = Steel

Dead Blow Hammer DB

Hammer head covered with Urethane and a dead blow function using steel balls to cushion the shock and reduce recoil. Soft faces that are gentle on the work piece and non-sparking due to no exposed metal. Ergonomic handle in fibreglass with grip in Santoprene rubber.

- Soft face, doesn't damage surfaces or equipment.
- Dead blow function uses steel balls to cushion the shock and reduce recoil.
- Ergonomic handle in fibreglass with grip in Santoprene.
- Non-sparking, no exposed metal.
- Flat area on head allows upright storage.



Ref. no.	Model	Weight including shaft	Shaft	Ø	Shaft length	Qty/pack
823411	DB 600	570 g	G	43 mm	240 mm	2 pcs
823412	DB 1200	1160 g	G	50 mm	282 mm	2 pcs
823413	DB 1600	1650 g	G	60 mm	342 mm	1 pcs
823414	DB 5000	5700 g	G	88 mm	838 mm	1 pcs

Copper Hammer CU

Hammer with copper head and fibreglass shaft. Copper hammers are spark-free and gentle on workpieces.

- Soft copper head is gentle on workpieces.
- For work in spark-free environments.
- Fibreglass shaft affords a greater level of safety and an extended service life.



Ref. no.	Model	Weight including shaft	Shaft	Shaft length	Qty/pack
823031	CU 300	400 g	G	260 mm	2 pcs
823032	CU 1000	1300 g	G	340 mm	2 pcs
823034	CU 2000	2400 g	G	340 mm	2 pcs
823035	CU 3000	4100 g	G	850 mm	1 pcs
823036	CU 4000	5200 g	G	850 mm	1 pcs
823037	CU 5000	5400 g	G	850 mm	1 pcs

Non-rebound Hammer STFS

Hammer with steel striking head filled with damping steel balls. The head has replaceable nylon strikers (hardness 70 shore) that are gentle on workpieces. Steel shaft with ergonomic Santoprene rubber handle.

- The head is filled with steel balls that dampen vibrations and reduce recoil.
- Replaceable nylon strikers hardness 70 shore that are gentle on work pieces (available as spares).
- Steel shaft with ergonomic handle in Santoprene rubber.



Ref. no.	Model	Weight including shaft	Shaft	Striker Ø	Spare strikers	Qty/pack
823312	STFS 30	595 g	S	30 mm	827547	2 pcs
823314	STFS 40	800 g	S	40 mm	827549	2 pcs
823315	STFS 50	1145 g	S	50 mm	827551	2 pcs
823316	STFS 60	1625 g	S	60 mm	827552	1 pcs

Rubber Mallet GU

A mallet with black solid rubber head, hardness 80/90 shore A. Ash shaft.

Ref. no.	Model	Weight including shaft	Shaft	Striker Ø	Qty/pack
823051	GU 40	165 g	A	40 mm	2 pcs
823052	GU 55	320 g	A	55 mm	2 pcs
823053	GU 65	550 g	A	65 mm	1 pcs
823054	GU 75	820 g	A	75 mm	1 pcs



A = Ash G = Fibreglass H = Hickory S = Steel



Powerful heads. All our sledge heads are made from high grade steel, correctly tempered in order to imbue them with the best possible levels of strength and durability, which in turn increases user safety.

Strong shafts. The shafts used on our sledges are made from American-grown hickory or fibreglass. Hickory is a strong and flexible wood that has long been used to make various types of shaft. Fibreglass shafts afford a greater level of safety and an extended service life.

NOTE! Strike right! Never strike a sledge against another piece of tempered steel! If a splinter is struck off from any part, it may cause serious injury. Therefore, you should always use protective goggles.

The right strike. Our sledge range includes sledges for wood, stone/rock and metal. Choosing the right sledge with the right head will make your work both safer and more efficient.

SLEDGES YOU CAN RELY ON.



Our sledges are made to handle tough conditions. They are forged in high-grade steel that is tempered in order to be extra durable. The shafts are made from strong and flexible hickory wood, which is considered to be the best variety for this type of shaft. However, it's also important that sledges are used in the right way. But most important of all is that you do not strike a sledge against another piece of tempered steel!

If a splinter were to come off as the result of such a strike, it may have the same effect as if a bullet had been fired from a small calibre gun. To protect your vision, you should always wear protective goggles whenever you use your sledge. Also remember not to store your sledge near to any heat sources as there is a danger that the wood may shrink, causing the head to come loose.

Sledge Double-faced KS

Sledge made from blasted and clear-lacquered ironwork, with tempered square striking faces at both ends. The shaft is 900 mm long and is made from hickory.

- Made from high-grade steel, correctly tempered for the best possible level of user safety.
- The wooden shaft is available as a spare.
- NOTE! Always wear protective goggles!



Ref. no.	Model	Weight	Shaft length	Shaft	Spare shaft	Qty/pack
825001	KS 4000	4000 g	900 mm	H	842050	1 pcs
825002	KS 5000	5000 g	900 mm	H	842050	1 pcs
825003	KS 6000	6000 g	900 mm	H	842050	1 pcs

Sledge Double-faced KS, Fibreglass

Sledge made from blasted and clear-lacquered ironwork, with tempered square striking faces at both ends. Has an 850 mm long fibreglass shaft with a rubber grip.

- Made from high-grade steel, correctly tempered for the best possible level of user safety.
- Fibreglass shaft affords a greater level of safety and an extended service life.
- NOTE! Always wear protective goggles!



Ref. no.	Model	Weight	Shaft length	Shaft	Spare shaft	Qty/pack
825041	KS 4000 G	4000 g	850 mm	G	-	1 pcs
825042	KS 5000 G	5000 g	850 mm	G	-	1 pcs
825043	KS 6000 G	6000 g	850 mm	G	-	1 pcs

Sledge STS

Stone sledge made from blasted and clear-lacquered ironwork, with a tempered square striking face at one end and a straight pein at the other. The shaft is 900 mm long and is made from hickory.

- Made from high-grade steel, correctly tempered for the best possible level of user safety.
- The wooden shaft is available as a spare.
- NOTE! Always wear protective goggles!



Ref. no.	Model	Weight	Shaft length	Shaft	Spare shaft	Qty/pack
825010	STS 3000	3000 g	900 mm	H	842050	1 pcs
825011	STS 4000	4000 g	900 mm	H	842050	1 pcs
825012	STS 5000	5000 g	900 mm	H	842050	1 pcs

Sledge STS, Fibreglass

Sledge made from blasted and clear-lacquered ironwork, with tempered square striking faces at one end and a straight pein at the other. Has an 850 mm long fibreglass shaft with a rubber grip.

- Made from high-grade steel, correctly tempered for the best possible level of user safety.
- Fibreglass shaft affords a greater level of safety and an extended service life.
- NOTE! Always wear protective goggles!



Ref. no.	Model	Weight	Shaft length	Shaft	Spare shaft	Qty/pack
825050	STS 3000 G	3000 g	850 mm	G	-	1 pcs
825051	STS 4000 G	4000 g	850 mm	G	-	1 pcs
825052	STS 5000 G	5000 g	850 mm	G	-	1 pcs

G = Fibreglass H = Hickory



Sledgehammer SMH

Sledgehammer made from black painted ironwork, with a tempered square striking face at one end and a cross pein at the other. Hickory shaft.

- Made from high-grade steel, correctly tempered for the best possible level of user safety.
- The wooden shaft is available as a spare.
- NOTE! Always wear protective goggles!

Ref. no.	Model	Weight	Shaft length	Shaft	Spare shaft	Qty/pack
843103	SMH 3000	3000 g	750 mm	H	842080	1 pcs
843104	SMH 4000	4000 g	750 mm	H	842080	1 pcs
843105	SMH 5000	5000 g	800 mm	H	842081	1 pcs
843106	SMH 6000	6000 g	800 mm	H	842081	1 pcs



Sledgehammer SRP

Sledgehammer made from black painted ironwork, with a tempered square striking face at one end and a straight pein at the other. Hickory shaft.

- Made from high-grade steel, correctly tempered for the best possible level of user safety.
- The wooden shaft is available as a spare.
- NOTE! Always wear protective goggles!

Ref. no.	Model	Weight	Shaft length	Shaft	Spare shaft	Qty/pack
843204	SRP 4000	4000 g	750 mm	H	842080	1 pcs



Sledgehammer Double-faced MH

Sledgehammer made from black painted ironwork, with tempered square striking faces at both ends. Hickory shaft.

- Made from high-grade steel, correctly tempered for the best possible level of user safety.
- The wooden shaft is available as a spare.
- NOTE! Always wear protective goggles!

Ref. no.	Model	Weight	Shaft length	Shaft	Spare shaft	Qty/pack
843303	MH 3000	3000 g	750 mm	H	842080	1 pcs
843304	MH 4000	4000 g	750 mm	H	842080	1 pcs
843305	MH 5000	5000 g	800 mm	H	842081	1 pcs
843306	MH 6000	6000 g	800 mm	H	842081	1 pcs



Sledge Double-faced HHK

Sledgehammer with black painted ironwork, tempered hexagon striking face on both sides. Wooden handle.

- NOTE! Always wear protective goggles!

Ref. no.	Model	Weight	Shaft length	Shaft	Spare shaft	Qty/pack
867001	HHK 4	4000 g	750 mm	H	-	1 pcs

G = Fibreglass H = Hickory



Copper Sledge CU

Sledge with copper head and fibreglass shaft. These sledges are spark-free and gentle on workpieces.

- Soft copper head is gentle on workpieces.
- For work in spark-free environments.
- Fibreglass shaft affords a greater level of safety and an extended service life.

Ref. no.	Model	Weight including shaft	Shaft	Shaft length	Qty/pack
823031	CU 300	400 g	G	260 mm	2 pcs
823032	CU 1000	1300 g	G	340 mm	2 pcs
823034	CU 2000	2400 g	G	340 mm	2 pcs
823035	CU 3000	4100 g	G	850 mm	1 pcs
823036	CU 4000	5200 g	G	850 mm	1 pcs
823037	CU 5000	5400 g	G	850 mm	1 pcs



Count on all the power you need - in three directions with reduced recoil.



The flat area on the head allows you to store it upright.



The Urethane covered hammerhead is filled with steel bearings to effectively cushion the shock and reduce recoil.



The soft yet hardwearing Urethane makes it gentle on the work piece while at the same time eliminating the risk of sparks. Non-sparking due to no exposed metal.

The dead blow hammers are available in wide range of sizes and weights.

The fibreglass handle features an ergonomic design and is clad Santoprene rubber for a truly safe grip.

Dead Blow Hammer DB

Hammer head covered with Urethane and a dead blow function using steel balls to cushion the shock and reduce recoil. Soft faces that are gentle on the work piece and non-sparking due to no exposed metal. Ergonomic handle in fibreglass with grip in Santoprene rubber.

- Soft face, doesn't damage surfaces or equipment.
- Dead blow function uses steel balls to cushion the shock and reduce recoil.
- Ergonomic handle in fibreglass with grip in Santoprene.
- Non-sparking, no exposed metal.
- Flat area on head allows upright storage.

Ref. no.	Model	Weight including shaft	Shaft	Ø	Shaft length	Qty/pack
823411	DB 600	570 g	G	43 mm	240 mm	2 pcs
823412	DB 1200	1160 g	G	50 mm	282 mm	2 pcs
823413	DB 1600	1650 g	G	60 mm	342 mm	1 pcs
823414	DB 5000	5700 g	G	88 mm	838 mm	1 pcs

G = Fibreglass



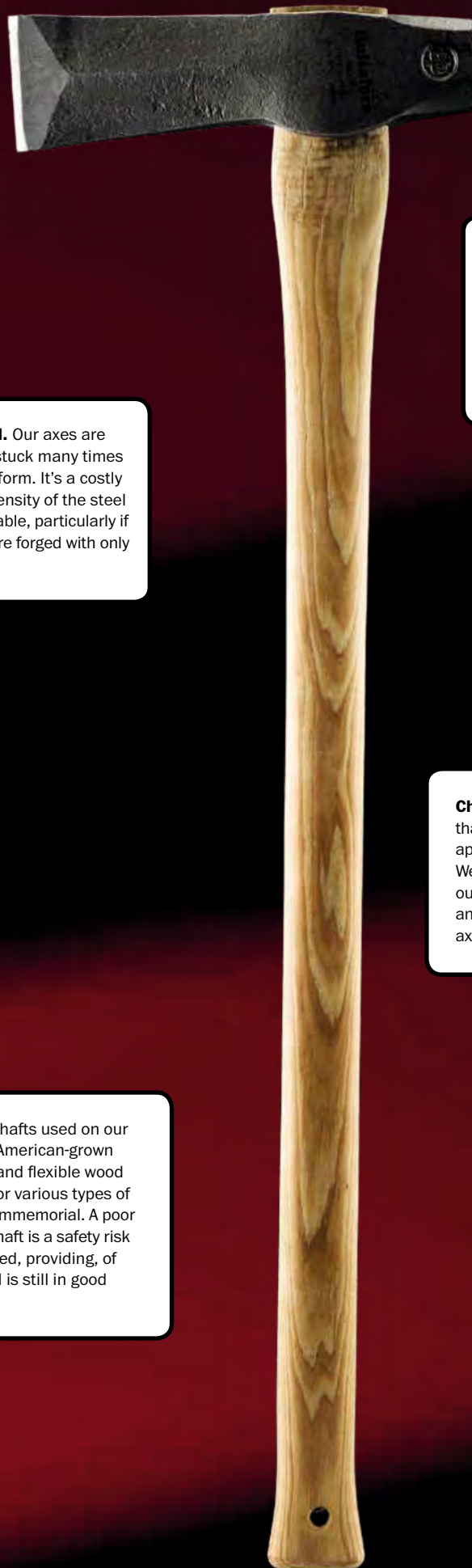

Craftsmanship personified. Our axes are forged by hand. The steel is struck many times until the axe attains its final form. It's a costly method, but increases the density of the steel and makes the axe extra durable, particularly if you compare it to axes that are forged with only a few strikes.

Powerful material. Our axes are made from Swedish axe steel that is of a consistently high quality. When we harden the steel, we do so using a method that leaves a clear hardened zone in the axe. Within this zone, the axe can be resharpened without detracting from the strength of the edge.

Choose the right axe! We produce axes that are designed for a number of different applications, including felling and splitting. We also produce axes that can be used outside the workplace - hunting, camping and sports. Regardless of the situation, all axes must be treated with the utmost care.

Strong shafts. The shafts used on our axes are made from American-grown hickory. It's a strong and flexible wood that has been used for various types of tool shaft since time immemorial. A poor quality or damaged shaft is a safety risk and should be replaced, providing, of course, that the head is still in good condition.

AXES FORGED WITH TRADITION.

Our axes have been crafted in the traditional way since 1697. At Hults Bruk in Östergötland, there are smiths who carry out work that not many others are able to do. Only a few producers in the world employ smiths who can produce this sort of craftsmanship.

Axe heads are forged from Swedish axe steel of a consistently high quality. The steel is struck many times until the axe attains its final form. This increases the density of the steel and thereby the durability and life of the axe. Our hardening method leaves a clear hard zone within which the axe can be sharpened whilst not detracting from the strength of the edge. Used correctly, our axes can last for generations.





Hatchet

A small axe for outdoor use in forests and open land. Made from blasted and clear-lacquered ironwork, it is also suitable for work in the garden. The shaft is curved and made from hickory. An edge protector is included.

- The axe is hand-forged and made from Swedish axe steel using traditional methods in use since 1697.
- The steel is stuck many times, increasing its density and thereby the durability of the axe.
- Has a clear tempered zone within which the axe can be sharpened whilst not detracting from the strength of the edge.
- The shaft is made from hickory and treated with linseed oil.

Ref. no.	Model	Weight	Shaft length	Shaft	Spare shaft	Qty/pack
840025	H 006 SV	600 g	375 mm 15.0"	H	842000	4 pcs
840066	H 008 SV	800 g	440 mm 17.5"	H	842003	4 pcs
840086	H 009 SV	900 g	500 mm 20.0"	H	842003	4 pcs
840642	HB EG 80 Spare edge protector for 840025					
840640	HB EG 95 Spare edge protector for 840066 and 840086					

Felling Axe HY 10

An axe suitable for small-scale felling, made from blasted and clear-lacquered ironwork. The shaft is curved and made from hickory.

- The axe is hand-forged and made from Swedish axe steel using traditional methods in use since 1697.
- The steel is stuck many times, increasing its density and thereby the durability of the axe.
- Has a clear tempered zone within which the axe can be sharpened whilst not detracting from the strength of the edge.
- The shaft is made from hickory and treated with linseed oil.

Ref. no.	Model	Weight	Shaft length	Shaft	Spare shaft	Qty/pack
840063	HY 10-0,8 SV	800 g	650 mm 26"	H	842007	4 pcs
840085	HY 10-0,9 SV	900 g	650 mm 26"	H	842007	4 pcs
840108	HY 10-1,0 SV	1000 g	700 mm 28"	H	842008	4 pcs
840144	HY 10-1,2 SV	1200 g	700 mm 28"	H	842008	4 pcs
840185	HY 10-1,5 SV	1500 g	800 mm 32"	H	842010	4 pcs

Felling Axe HY 20

An axe suitable for small-scale felling, made from blasted and clear-lacquered ironwork. The shaft is curved and made from hickory. Particularly suitable for lopping branches or clearing bushes and brushwood.

- The axe is hand-forged and made from Swedish axe steel using traditional methods in use since 1697.
- The steel is stuck many times, increasing its density and thereby the durability of the axe.
- Has a clear tempered zone within which the axe can be sharpened whilst not detracting from the strength of the edge.
- The shaft is made from hickory and treated with linseed oil.

Ref. no.	Model	Weight	Shaft length	Shaft	Spare shaft	Qty/pack
840281	HY 20-0,85 SV	850 g	650 mm 26"	H	842007	4 pcs

Felling Axe HHY

Felling axe with black painted ironwork. The shaft is curved and made from birch.

Ref. no.	Model	Weight	Shaft length	Shaft	Spare shaft	Qty/pack
840058	HHY 0.5-375	500 g	375 mm 15"	BR	-	4 pcs
840068	HHY 0.9-650	900 g	650 mm 26"	BR	-	4 pcs

Carpenter's Axe SY RA

Blasted and clear-lacquered ironwork with a notch in the head near the shaft, allowing you to hold a hand directly above the edge while cutting. The shaft is straight and made from hickory.

- The axe is hand-forged and made from Swedish axe steel using traditional methods in use since 1697.
- The steel is stuck many times, increasing its density and thereby the durability of the axe.
- Has a clear tempered zone within which the axe can be sharpened whilst not detracting from the strength of the edge.
- The shaft is made from hickory and treated with linseed oil.

Ref. no.	Model	Weight	Shaft length	Shaft	Spare shaft	Qty/pack
840303	SY 21-0,8 RA	800 g	500 mm 20"	H	842002	4 pcs
840325	SY 21-1,0 RA	1000 g	500 mm 20"	H	842002	4 pcs

BR = Birch H = Hickory

Carpenter's Axe SY SV

Blasted and clear-lacquered ironwork with a notch in the head near the shaft, allowing you to hold a hand directly above the edge while cutting. The shaft is curved and made from hickory.

- The axe is hand-forged and made from Swedish axe steel using traditional methods in use since 1697.
- The steel is stuck many times, increasing its density and thereby the durability of the axe.
- Has a clear tempered zone within which the axe can be sharpened whilst not detracting from the strength of the edge.
- The shaft is made from hickory and treated with linseed oil.

Ref. no.	Model	Weight	Shaft length	Shaft	Spare shaft	Qty/pack
840304	SY 21-0,8 SV	800 g	500 mm 20"	H	842003	4 pcs
840326	SY 21-1,0 SV	1000 g	500 mm 20"	H	842003	4 pcs

Splitting Axe KLY RA

Splitting axe made from blasted and clear-lacquered ironwork. Heavier axe ideally suited for splitting heavy wood. The shaft is straight and made from hickory.

- The axe is hand-forged and made from Swedish axe steel using traditional methods in use since 1697.
- The steel is stuck many times, increasing its density and thereby the durability of the axe.
- Has a clear tempered zone within which the axe can be sharpened whilst not detracting from the strength of the edge.
- The shaft is made from hickory and treated with linseed oil.

Ref. no.	Model	Weight	Shaft length	Shaft	Spare shaft	Qty/pack
840592	KLY 7-1,5 RA	1500 g	750 mm 30"	H	842009	2 pcs

Splitting Axe KLY SV

Splitting axe made from blasted and clear-lacquered ironwork. The heavier axe is best suited to stronger wood, while the lighter axe is best suited to basic splitting of 'kindling wood'. The shaft is curved and made from hickory.

- The axe is hand-forged and made from Swedish axe steel using traditional methods in use since 1697.
- The steel is stuck many times, increasing its density and thereby the durability of the axe.
- Has a clear tempered zone within which the axe can be sharpened whilst not detracting from the strength of the edge.
- The shaft is made from hickory and treated with linseed oil.

Ref. no.	Model	Weight	Shaft length	Shaft	Spare shaft	Qty/pack
840581	KLY 7-0,9 SV	900 g	500 mm 20"	H	842003	4 pcs
840593	KLY 7-1,5 SV	1500 g	750 mm 30"	H	842010	2 pcs

Splitting Axe HKLY

Splitting axe with black painted ironwork. The shaft is curved and made from birch.

Ref. no.	Model	Weight	Shaft length	Shaft	Spare shaft	Qty/pack
840078	HKLY 1.4-650	1400 g	650 mm 26"	BR	-	2 pcs

Splitting Axe SLY

Our most powerful and heaviest splitting axe, made from blasted and clear-lacquered ironwork. Has a tempered striking face at the back of its head and can therefore also be used as a sledge. NOTE: never strike the tempered striking face against other tempered objects. The shaft is straight and made from hickory.

- Has a tempered striking face at the back of its head and can therefore also be used as a sledge.
- The axe is hand-forged and made from Swedish axe steel using traditional methods in use since 1697.
- The steel is stuck many times, increasing its density and thereby the durability of the axe.
- Has a clear tempered zone within which the axe can be sharpened whilst not detracting from the strength of the edge.
- The shaft is made from hickory and treated with linseed oil.

Ref. no.	Model	Weight	Shaft length	Shaft	Spare shaft	Qty/pack
840601	SLY 141-2,5 RA	2500 g	800 mm 32"	H	842011	2 pcs



BR = Birch H = Hickory



Trekking Axe Mini – Classic

Our smallest outdoors axe, hand-forged and made from Swedish axe steel using traditional methods in use since 1697. The steel is stuck many times, increasing its density and thereby the durability of the axe. Perfect for packing in a rucksack, the axe can also be worn on a belt.

- Has a clear tempered zone within which the axe can be sharpened whilst not detracting from the strength of the edge.
- An edge protector (item no. 840765) is included with the axe, but is also available to purchase separately as a spare.
- Hickory shaft.
- Presented in a gift box.

Ref. no.	Model	Weight	Shaft length	Shaft	Spare shaft	Qty/pack
840760	HB FY-0,5 MINI	500 g	235 mm	H	842075	1 pcs
840765	HB EG-FY Spare edge protector					



Trekking Axe – Classic

A small, practical outdoors axe, hand-forged and made from Swedish axe steel using traditional methods in use since 1697. The steel is stuck many times, increasing its density and thereby the durability of the axe. Excellent for use in the great outdoors, can tackle most jobs.

- Can be attached to a belt.
- Has a clear hard zone within which the axe can be sharpened whilst not detracting from the strength of the edge.
- An edge protector (item no. 840765) is included with the axe, but is also available to purchase separately as a spare.
- Hickory shaft.
- Presented in a gift box.

Ref. no.	Model	Weight	Shaft length	Shaft	Spare shaft	Qty/pack
840701	HB FY-0,5	500 g	375 mm	H	842085	1 pcs
840765	HB EG-FY Spare edge protector					



Felling Axe – Classic

An axe suitable for small-scale felling,, hand-forged and made from Swedish axe steel using traditional methods in use since 1697. The steel is stuck many times, increasing its density and thereby the durability of the axe. Particularly suitable for lopping branches or clearing bushes and brushwood.

- An edge protector (item no. 840715) is included with the axe, but is also available to purchase separately as a spare.
- Has a clear tempered zone within which the axe can be sharpened whilst not detracting from the strength of the edge.
- Hickory shaft.

Ref. no.	Model	Weight	Shaft length	Shaft	Spare shaft	Qty/pack
840720	HB HY-0,85	850 g	650 mm 26"	H	842007	1 pcs
840715	EG-JY Spare edge protector					



Hunting Axe – Classic

A slightly more powerful axe with a rounded neck, hand-forged and made from Swedish axe steel using traditional methods in use since 1697. The steel is stuck many times, increasing its density and thereby the durability of the axe. Ideal for hunters who both skin animals and carry out light forest work.

- An edge protector (item no. 840715) is included with the axe, but is also available to purchase separately as a spare.
- Has a clear tempered zone within which the axe can be sharpened whilst not detracting from the strength of the edge.
- Hickory shaft.

Ref. no.	Model	Weight	Shaft	Shaft length	Spare shaft	Qty/pack
840710	HB JY-0,85	850 g	H	500 mm	842003	1 pcs
840715	EG-JY Spare edge protector					

H = Hickory

Carpenter's Axe – Classic

Axe with a thin, long and straight knife-ground edge, hand-forged and made from Swedish axe steel using traditional methods in use since 1697. The steel is stuck many times, increasing its density and thereby the durability of the axe. Has a notch in the head near the shaft, allowing you to hold a hand directly above the edge while cutting.

- An edge protector (item no. 840735) is included with the axe, but is also available to purchase separately as a spare.
- Has a clear tempered zone within which the axe can be sharpened whilst not detracting from the strength of the edge.
- Hickory shaft.

Ref. no.	Model	Weight	Shaft length	Shaft	Spare shaft	Qty/pack
840730	HB SY-0,85	850 g	500 mm	H	842002	1 pcs
840735	EG-SY Spare edge protector					



Throwing Axe – Classic

Double-edged axe, hand-forged and made from Swedish axe steel using traditional methods in use since 1697. The steel is stuck many times, increasing its density and thereby the durability of the axe. Was originally designed as an axe for forest work, but is now primarily used in axe throwing competitions.

- An edge protector (item no. 840755) is included with the axe, but is also available to purchase separately as a spare.
- Has a clear tempered zone within which the axe can be sharpened whilst not detracting from the strength of the edge.
- Hickory shaft.

Ref. no.	Model	Weight	Shaft length	Shaft	Spare shaft	Qty/pack
840750	HB KY-1,6	1500 g	760 mm	H	842015	1 pcs
840755	EG-KY Spare edge protector					



Wedge

A complementary tool for splitting axes that makes it easier to split particularly thick pieces of wood. Use the tempered striking surface at the back of the sledge axe or a tempered steel sledge when working using a wedge.

- Made from red painted steel.
- Not tempered, allowing you to use tempered tools in conjunction with the wedge.

Ref. no.	Model	Weight	Qty/pack
840620	VK 1200 RA	1200 g	2 pcs



H = Hickory



 **Hultafors**
CLASSIC

SHARPEN, STORE AND USE.

Sharpening. Use a convex edge for applications such as delimiting, felling and splitting (1). Use a straight edge for hacking (2). An axe that has been sharpened at an angle is dangerous to use as it can easily slip! (3). A concave edge entails a high risk of the axe splintering (4). You can sharpen your axe edge using sandpaper or a bench grinder. The safest way to sharpen is using a wet grinder, but sometimes it may be necessary to first grind out burrs or other damage using a different method, e.g. a bench grinder.

NB: It is very important that you take care when sharpening and ensure that the axe is not affected by heat! If any part of the axe turns a blue colour, it signals that its tempered zone has disappeared in that part of the axe and it is no longer as resistant to wear.

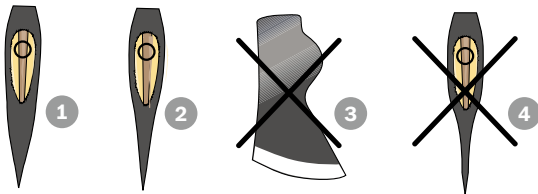

Storage Never store your axe in excessively dry places, e.g. in boiler rooms or leaning against a heater. You then risk the shaft drying out and the axe head coming loose whilst being used.

Use. Never strike the neck of the axe with another tool. Never use the axe as a sledge. Only sledge axes can withstand being used as a sledge.



RE-HANDLE.

Re-handle. If an axe, sledge or hammer breaks, it is almost always the shaft/handle that is the culprit. A poor quality or damaged shaft is a major safety risk. However, if the head is still in good condition, you can re-use your tool by fitting a new shaft. When fitting a new shaft to your tool, it's important to ensure that the shaft is dry. If it's not and dries after the head as been fitted, there is a danger that the head will come loose. This also applies to the wedge if you fit a new shaft using a wooden wedge.

Shaft key

- A = Ash
- S = Steel
- G = Fibreglass
- H = Hickory
- B = Beech

Model designation key

BHS 295 - 19 x 11
 ↓ ↓ ↓
 Model Length Eye

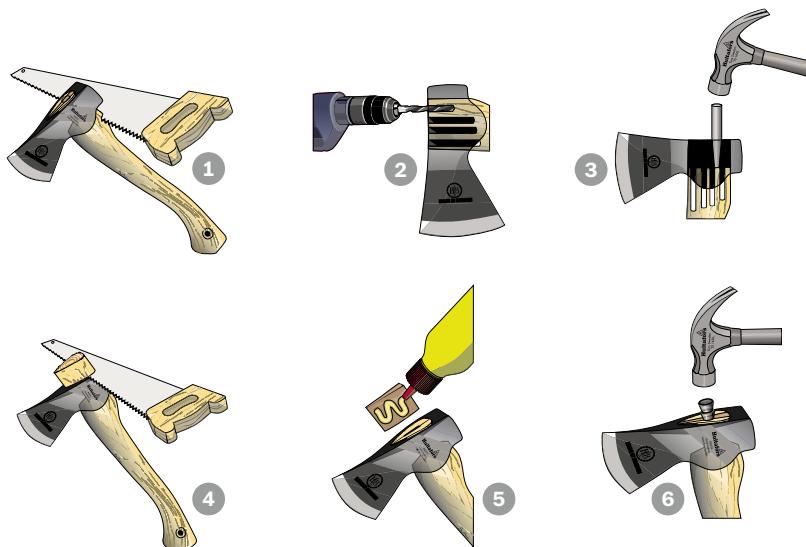

To fit a new shaft, do the following:

1. Cut off the existing shaft just below the head.
2. Drill a number of holes in the eye.
3. Tap out what is left and clean the eye.
4. Press and tap the head onto the new shaft, firmly but carefully. Cut off the protruding part of the shaft.
5. Fit the steel wedge so that the end of the shaft fills the eye. If the steel wedge is not sufficient, you should fit a wooden wedge before the steel wedge. You can make this by cutting a wedge from a dry piece of hard timber. Then split the end of the shaft using a chisel. Apply some wood glue, tap in the wooden wedge and then cut off the excess.
6. Tap the steel wedge out so that it locks the wooden wedge in position. Then apply oil to the end of the shaft to protect it against moisture.



Steel Wedge Round, 2-pack.

Ref. no.	Model	Ø	Length	Fits to	Qty/pack
828600	SK 9 SB	9 mm	14.5 mm	AB 400, 600 XK 400, 500, SH 200	10 pcs
828601	SK 11 SB	11 mm	16.5 mm	Z 800, 900, 1000, MH 1000	10 pcs
828602	SK 12 SB	12 mm	17.5 mm	Z 1200, 1500, 2000, B 600, 800, ME 1000, 1200, 1500, M 600, KP 650, 750	10 pcs
828603	SK 16 SB	16 mm	22 mm	KS 3000, KS 4000, KS 5000, STS 3000, STS 4000, STS 5000, SMH 3000, MH 3000, Axe 0.6 kg, 0.8 kg, 0.85 kg, 0.9 kg, 1.0 kg, 1.2 kg	10 pcs
828604	SK 17 SB	17 mm	23 mm	SMH 4000, 5000, 6000, MH 4000, 5000, 6000 Axe 1.5 kg, 1.6 kg, 2.5 kg	10 pcs



Hammer shaft

Ref. no.	Model	Wood variety	Fits to	Wedge	Qty	Qty/pack
827001	HS 290-12x9	H	AB 150, XK 150	-	-	5 pcs
827002	HS 310-15x10	H	AB 200, 300, XK 200, 300, GMH 150	-	-	5 pcs
827004	HS 330-17x11	H	AB 400, 600, XK 400, 500	SK 9	1 pcs	5 pcs
827206	HS 375-21x14	H	Z 800, 900, 1000	SK 11	1 pcs	5 pcs
827208	HS 410-25x18	H	Z 1200, 1500, 2000	SK 12	1 pcs	5 pcs
827222	MHS 305-22x17	H	ME 1000, 1200, 1500	SK 12	1 pcs	5 pcs
827231	LHS 350-22x12	H	KP 650, 750	SK 12	1 pcs	5 pcs
827085	BHS 280-20x12	H	B 200	SK 9	1 pcs	5 pcs
827086	BHS 300-22x13	H	B 300, 400	SK 9	1 pcs	5 pcs
827261	MHS 270-D24	H	M 500, 600	SK12	1 pcs	5 pcs
827070	BHS 295-19x11	H	SH 200	SK 9	1 pcs	5 pcs
827071	BHS 315-22x13	H	SH 250, 400	SK 9	1 pcs	5 pcs
842073	SHS 380-32x19	H	SMH 1000, 1500	SK 12	2 pcs	5 pcs
842074	SHS 400-36x21	H	SMH 2000	SK 12	2 pcs	5 pcs
842091	MHS 280-31x21	H	MH 1000, 1250, 1500	SK 12	2 pcs	5 pcs
842092	MHS 300-37x21	H	MH 2000	SK 12	2 pcs	5 pcs

H = Hickory

Sledge Shaft Straight With Steel Wedge



Ref. no.	Model	Wood variety	Fits to	Wedge	Qty	Qty/pack
842050	SSR 900-41x32	H	KS 4000, 5000, 6000, STS 3000, 4000, 5000	SK 16	2 pcs	5 pcs
842080	SSR 750-42x24	H	SRP 4000, SMH 3000, 4000, MH 3000, 4000	SK 16	2 pcs	5 pcs
842053	SSR 900-45x35	H	-	-	-	5 pcs
842081	SSR 800-47x27	H	SMH 5000, 6000, MH 5000, 6000	SK 17	2 pcs	5 pcs
842054	SSR 900-50x36	H	-	SK 17	2 pcs	5 pcs

Axe Shaft Curved With Wooden Wedge



Ref. no.	Model	Wood variety	Fits to	Wedge	Qty	Qty/pack
842000	YSS 375-50x20	H	H 006	SK 16	1 pcs	5 pcs
842003	YSS 500-50x20	H	H 008, H 009, KLY 7-0.9, HB JY-0.85	SK 16	1 pcs	5 pcs
842007	YSS 650-50x20	H	HY 10-0.8 - 0.9, HY 20-0.85, HB JY-0.7	SK 16	1 pcs	5 pcs
842008	YSS 700-50x20	H	HY 10-1.0-1.2	SK 16	1 pcs	5 pcs
842010	YSS 750-63x23	H	KLY 7-1.5, HY 10-1.5	SK 17	1 pcs	5 pcs
842085	YSS 375-43x18	H	HB FY-0.5	SK 12	1 pcs	5 pcs
842075	YSS 235-43X18	H	HB FY-0.5 MINI	SK 12	1 pcs	5 pcs

Axe Shaft Straight With Wooden Wedge



Ref. no.	Model	Wood variety	Fits to	Wedge	Qty	Qty/pack
842002	YSR 500-50x20	H	SY 21-0.8 - 1.0, HB SY0.85	SK 16	1 pcs	5 pcs
842009	YSR 750-63x23	H	KLY 7-1.5, HB KLY-1.5	SK 17	1 pcs	5 pcs
842011	YSR 800-55x27	H	Sly 141-2.5	SK 17	2 pcs	5 pcs
842015	YSR 760-60X17	H	HB KY-1.6	SK 17	1 pcs	5 pcs

Shaft Straight



Ref. no.	Model	Wood variety	Fits to	Wedge	Qty	Qty/pack
842042	KS 900-72x40	B	Pick head, small eye	-	-	5 pcs
842062	HS 900-75x53	B	Pick head, large eye	-	-	5 pcs

B = Beech H = Hickory



Steel with strength. The blades of our knives are made from Japanese steel, which is renowned for its high quality. The cutting edge is sharpened in several stages and is given a final honing on a leather strop. This makes the blade very durable and gives it a really sharp edge.

A knife for you. Essentially, knives haven't changed in over 100 years. But now, after working together with the experts – professional craftsmen – we have developed a unique range of knives. Specially designed according to how craftsmen actually work.

Tough plastic. Both the handle and holster are made from super-durable polypropylene – PP plastic. The handle is designed to give you a safe and comfortable grip. A unique function means that the holster does not detach from the button in your trousers, whilst at the same time being easy to remove.

Unique functions. Our range includes knives with smart features that make your job easier. For example, our chisel knife can also be used as a chisel. All this means that you can use your knife in several ways without damaging it.

Double holster. If you need more than one knife when you're working, you can avail yourself of our smart double holster. It allows you to create a knife set-up that best suits your requirements.

CRAFTSMAN'S KNIVES – TAILORED TO YOUR REALITY.



When we were developing our craftsman's knives, we got help from the real experts – professional craftsmen. We studied what they did, listened to what they wanted and tried to identify their needs. We made prototypes that were tested by them out in the field, made changes and tested them again. The final result was a unique range of knives tailored specifically to how craftsmen actually work.

The knife blades are made from Japanese steel, with all edges sharpened in multiple stages, followed by a final honing on a leather strop. Both the handle and holster are made from super-durable polypropylene – PP plastic. We have used different colours for the handles so that you can easily recognise your favourite knives.

HEAVY-DUTY AND CHISEL KNIVES

These are powerful and durable knives that can be used for most jobs that require prizing, breaking, chiselling and hacking various different materials.

PAINTER'S KNIFE

The painter's knife is a triple-function tool. First and foremost, it is a knife, but it is also a screwdriver and a can opener.

PLUMBER'S KNIFE

As plumbers frequently need to remove burrs from pipes, the plumber's knife features an integrated file on one side of the blade.

HOLSTER

You simply attach the holster to a button on your trousers using a unique function that ensures that the holster doesn't come loose whilst still making it easy to remove. Insert the button into the hole, pull the holster down and snap the cover firmly in position.

To remove the holster, just undo the cover. The holster can also be worn on a belt. If you have a thick belt, you may need to cut off the pin on the cover.

DOUBLE HOLSTER

If you're used to carrying two knives at the same time, you may benefit from using a double holster. It allows you to easily carry the knife set-up that best suits your requirements.



Craftsman's Knife HVK

Knife developed and adapted to meet the needs of craftsmen, with a blade made from Japanese knife steel. It features a unique function for attaching the holster around a button on your work clothes so that it does not come loose whilst still being easy to remove. The blade is made from 2.5 mm carbon steel that has been hardened to 58–60 HRC.

- The cutting edge has been sharpened in several stages, with a final honing on a leather strop.
- Both the handle and holster are made from super-durable PP plastic.
- The holster can be attached to both a belt and a button on your work clothes. If your belt is thick, cut away the small pin on the cover.
- Knives in packs of 28 supplied in a cardboard counter display.
- Craftsman's knife HVK-PH is supplied with a cardboard case instead of a holster.

Craftsman's Knife HVK GH

Craftsman's knife with friction grip. Developed and adapted to the needs of craftsmen. It features a unique function for attaching the holster around a button on your work clothes so that it does not come loose whilst still being easy to remove. The blade is made from 2.5 mm carbon steel that has been hardened to 58–60 HRC.

- The cutting edge has been sharpened in several stages, with a final honing on a leather strop.
- The handle is made from super-durable PP plastic and fitted with a Santoprene friction grip.
- Fits in the same holster as the HVK model and its double holster.

Craftsman's Knife RFR

Knife developed and adapted to meet the needs of craftsmen, with a blade made from stainless Japanese knife steel. It features a unique function for attaching the holster around a button on your work clothes so that it does not come loose whilst still being easy to remove. The blade is made from 2.5 mm stainless steel that has been hardened to 57–59 HRC.

- The cutting edge has been sharpened in several stages, with a final honing on a leather strop.
- Both the handle and holster are made from super-durable PP plastic.
- The holster can be attached to both a belt and a button on your work clothes. If your belt is thick, cut away the small pin on the cover.
- Knives in packs of 28 supplied in a cardboard counter display.
- Craftsman's knife RFR-PH is supplied with a cardboard case instead of a holster. RFR fits in the same holster as HVK.

Craftsman's Knife RFR GH

Craftsman's knife with friction grip. Developed and adapted to the needs of craftsmen. It features a unique function for attaching the holster around a button on your work clothes so that it does not come loose whilst still being easy to remove. The blade is made from 2.5 mm stainless steel that has been hardened to 57–59 HRC.

- The cutting edge has been sharpened in several stages, with a final honing on a leather strop.
- The handle is made from super-durable PP plastic and fitted with a Santoprene friction grip.
- Fits in the same holster as the HVK model and its double holster.

Heavy Duty Knife GK

A powerful and durable ground knife suitable for tough tasks such as prizing, breaking and hacking. It features a unique function for attaching the holster around a button on your work clothes so that it does not come loose whilst still being easy to remove. The blade is made from Japanese knife steel, 3 mm carbon steel that has been hardened to 58–60 HRC.

- The cutting edge has been sharpened with a double edge angle and a final honing on a leather strop.
- Both the handle and holster are made from super-durable PP plastic.
- The holster can be attached to both a belt and a button on your work clothes. If your belt is thick, cut away the small pin on the cover.
- Because the heavy duty knife is a more powerful tool, it has a larger holster than other knives in the craftsmen range.
- GK-PH is supplied with a cardboard case instead of a holster.



Ref. no.	Model	Blade length	Total length	Qty/pack
380010	HVK	93 mm	208 mm	10 pcs
385010	HVK-PH	93 mm	208 mm	10 pcs
386030	HVK-28	93 mm	208 mm	28 pcs
386020	HVK-100	93 mm	208 mm	100 pcs



Ref. no.	Model	Blade length	Total length	Qty/pack
380210	HVK GH	93 mm	208 mm	10 pcs

Registered Community Design No. 001152821-1/2



Ref. no.	Model	Blade length	Total length	Qty/pack
380060	RFR	93 mm	208 mm	10 pcs
386060	RFR-28	93 mm	208 mm	28 pcs



Ref. no.	Model	Blade length	Total length	Qty/pack
380260	RFR GH	93 mm	208 mm	10 pcs

Registered Community Design No. 001152821-1/2



Ref. no.	Model	Blade length	Total length	Qty/pack
380020	GK	94 mm	222 mm	10 pcs

Chisel Knife STK

Robust knife with V-ground chisel function. It features a unique function for attaching the holster around a button on your work clothes so that it does not come loose whilst still being easy to remove. The blade is made from Japanese knife steel, 3 mm carbon steel that has been hardened to 58-60 HRC.

- The cutting edge has been sharpened with a double edge angle and a final honing on a leather strop.
- Both the handle and holster are made from super-durable PP plastic.
- The holster can be attached to both a belt and a button on your work clothes. If your belt is thick, cut away the small pin on the cover.
- Chisel knife STK-PH is supplied with a cardboard case instead of a holster. STK fits in the same holster as heavy duty knife GK.



Ref. no.	Model	Blade length	Total length	Qty/pack
380070	STK	72 mm	201 mm	10 pcs

Safety Knife SK

A knife designed with a dull point, developed and adapted to minimise sticking injuries. It features a unique function for attaching the holster around a button on your work clothes so that it does not come loose whilst still being easy to remove. The blade is made from Japanese knife steel, 2.5 mm carbon steel that has been hardened to 58-60 HRC.

- The cutting edge has been sharpened in several stages, with a final honing on a leather strop.
- Both the handle and holster are made from super-durable PP plastic.
- The holster can be attached to both a belt and a button on your work clothes. If your belt is thick, cut away the small pin on the cover.
- Safety knife SK fits in the same holster as HVK.



Ref. no.	Model	Blade length	Total length	Qty/pack
380080	SK	88 mm	203 mm	10 pcs

Registered Community Design No. 000857214-1/6

Safety Knife SKR

A knife designed with a dull point, developed and adapted to minimise sticking injuries. It features a unique function for attaching the holster around a button on your work clothes so that it does not come loose whilst still being easy to remove. The blade is made from Japanese knife steel, 2.5 mm stainless steel that has been hardened to 57-59 HRC.

- The cutting edge has been sharpened in several stages, with a final honing on a leather strop.
- Both the handle and holster are made from super-durable PP plastic.
- The holster can be attached to both a belt and a button on your work clothes. If your belt is thick, cut away the small pin on the cover.
- Safety knife SKR fits in the same holster as HVK.



Ref. no.	Model	Blade length	Total length	Qty/pack
380090	SKR	88 mm	203 mm	10 pcs

Registered Community Design No. 000857214-1/6

Electrician's Knife ELK

The sharpening of the blade edges and the design of the handle have been optimized for cable stripping. It features a unique function for attaching the holster around a button on your work clothes so that it does not come loose whilst still being easy to remove. The blade is made from Japanese knife steel, 1.5 mm carbon steel that has been hardened to 58-60 HRC.

- The two edges have been sharpened to be particularly effective when stripping cables.
- Both the handle and holster are made from super-durable PP plastic.
- The holster can be attached to both a belt and a button on your work clothes. If your belt is thick, cut away the small pin on the cover.
- ELK-L has a green handle with edges sharpened for left-handed use.



Ref. no.	Model	Blade length	Total length	Qty/pack
380030	ELK	33 mm	158 mm	10 pcs
383030	ELK-L	33 mm	158 mm	10 pcs

Electrician's Fitter Knife EFK

The thin blade, the sharpening of the blade edge and the design of the handle has been optimized for cable stripping. It features a unique function for attaching the holster around a button on your work clothes so that it does not come loose whilst still being easy to remove. The blade is made from Japanese knife steel, 1.5 mm carbon steel that has been hardened to 58-60 HRC.

- The thin blade has been sharpened to be particularly effective when stripping cables.
- Both the handle and holster are made from super-durable PP plastic.
- The holster can be attached to both a belt and a button on your work clothes. If your belt is thick, cut away the small pin on the cover.



Ref. no.	Model	Blade length	Total length	Qty/pack
380140	EFK	33 mm	158 mm	10 pcs

Painter's Knife MK

Knife for painters, designed for use as both a can opener and a slot screwdriver. It features a unique function for attaching the holster around a button on your work clothes so that it does not come loose whilst still being easy to remove. The blade is made from Japanese knife steel, 2.5 mm carbon steel that has been hardened to 58–60 HRC.

- The cutting edge has been sharpened in several stages, with a final honing on a leather strop.
- Both the handle and holster are made from super-durable PP plastic.
- The holster can be attached to both a belt and a button on your work clothes. If your belt is thick, cut away the small pin on the cover.
- Painter's knife MK fits in the same holster as HVK.



Ref. no.	Model	Blade length	Total length	Qty/pack
380040	MK	93 mm	208 mm	10 pcs

Registered Community Design No. 000245022-1/2

Plumber's Knife VVS

Plumber's knife featuring a file that can be used to remove burrs. It features a unique function for attaching the holster around a button on your work clothes so that it does not come loose whilst still being easy to remove. The blade is made from Japanese knife steel, 2.5 mm stainless steel that has been hardened to 57–59 HRC.

- The cutting edge has been sharpened in several stages, with a final honing on a leather strop.
- Both the handle and holster are made from super-durable PP plastic.
- The holster can be attached to both a belt and a button on your work clothes. If your belt is thick, cut away the small pin on the cover.
- The plumber's knife VVS fits in the same holster as HVK.



Ref. no.	Model	Blade length	Total length	Qty/pack
380050	VVS	93 mm	208 mm	10 pcs

Registered Community Design No. 000245022-1/2

Flexible Knife FXK

Craftsman's knife with a flexible blade adapted to work where a bendable blade is required such as removing paint and silicone from surface or where a thin blade is desired. It features a unique function for attaching the holster around a button on your work clothes so that it does not come loose whilst still being easy to remove. The blade is made from 0.8 mm carbon steel that has been hardened to 58–60 HRC.

- The cutting edge has been sharpened in several stages, with a final honing on a leather strop.
- Both the handle and holster are made from super-durable PP plastic.
- The holster can be attached to both a belt and a button on your work clothes. If your belt is thick, cut away the small pin on the cover.
- Flexible knife FXK fits in the same holster as HVK.



Ref. no.	Model	Blade length	Total length	Qty/pack
380120	FXK	93 mm	208 mm	10 pcs

Registered Community Design No. 000245022-1/2

Precision Knife PK GH

Craftsman's knife with friction grip adapted to work where more precision is required such as removing burr of plastic pipes, carving or places with limited access. It features a unique function for attaching the holster around a button on your work clothes so that it does not come loose whilst still being easy to remove. The blade is made from 2.0 mm carbon steel that has been hardened to 58–60 HRC.

- The cutting edge has been sharpened in several stages, with a final honing on a leather strop.
- Both the handle and holster are made from super-durable PP plastic.
- The holster can be attached to both a belt and a button on your work clothes. If your belt is thick, cut away the small pin on the cover.
- Precision knife PK GH fits in the same holster as HVK.



Ref. no.	Model	Blade length	Total length	Qty/pack
380220	PK GH	93 mm	208 mm	10 pcs

Registered Community Design No. 000245022-1/2

Insulation Knife

An insulation knife with a 50 mm wide, flexible blade and scale. Its serrated blade makes it easy to cut through all types of insulation wool. Grip-friendly handle made from impact-resistant PP plastic.

- The blade is made from 50 mm wide carbon steel.
- A serrated blade makes it easy to cut through all types of insulation wool.
- Both the handle and holster are made from super-durable PP plastic.



Ref. no.	Model	Blade length	Total length	Qty/pack
389010	FGK	316 mm	465 mm	5 pcs

KNIVES IN DOUBLE HOLSTER.

Double holster made from impact-resistant PP plastic, joined by rivets and hardwearing leather. A double holster always allows you to have access to the two knives you use the most. Available in five different

combinations. Once your knives have worn out, keep the holster and use it again with new knives.

2 HVK craftsmen's knives in a double holster

Ref. no.	Model	Blade length	Total length	Qty/pack
381010	HVK & HVK	93/93 mm	208/208 mm	4 pcs

Registered Community Design No. 000242250-1/2



Craftsmen's knife HVK and electrician's knife ELK in a double holster

Ref. no.	Model	Blade length	Total length	Qty/pack
381030	HVK & ELK	93/33 mm	208/158 mm	4 pcs

Registered Community Design No. 000242250-1/2



Heavy duty knife GK and craftsmen's knife HVK in a double holster

Ref. no.	Model	Blade length	Total length	Qty/pack
381020	GK & HVK	94/93 mm	222/208 mm	4 pcs

Registered Community Design No. 000242250-1/2



Chisel knife STK and craftsmen's knife HVK in a double holster

Ref. no.	Model	Blade length	Total length	Qty/pack
387010	STK & HVK	72/93 mm	201/208 mm	4 pcs

Registered Community Design No. 000242250-1/2



Chisel knife STK and electrician's knife ELK in a double holster

Ref. no.	Model	Blade length	Total length	Qty/pack
387030	STK & ELK	72/33 mm	201/158 mm	4 pcs

Registered Community Design No. 000242250-1/2

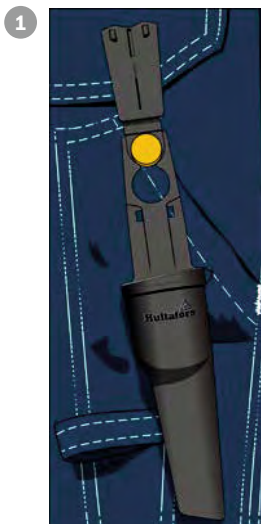

1. You simply attach the holster to a button on your trousers using a unique function that ensures that the holster doesn't come loose whilst still making it easy to remove.
2. Insert the button into the hole, pull the holster down and snap the cover firmly in position. To remove the holster, just undo the cover.
3. The holster can also be worn on a belt. If you have a thick belt, you may need to cut off the pin on the cover.

ADVANCED KNIVES – PLAIN AND SIMPLE.

A really good knife should sit perfectly in your hand and be easy to use. At the same time, it should be robust, reliable and possess all the important functions.

We know this, because we developed our new knives in conjunction with professional craftsmen who helped field test every single component. Only once they were completely satisfied did we know that our new range of knives matched up to the demanding day-to-day requirements of the job. You can easily open our new knives without tools and you can feed out and lock the blade in position with just one hand. They all feature a

comfortable and ergonomically designed finger grip that increases safety where power is required. In addition, all our knives have a narrowing tip, delivering a high level of precision at all times. To make our knives as user friendly as possible, we have eliminated all unnecessary components and minimised the number of moving parts. This extends the service life of the knife as there are fewer parts that can break or fall off. It also makes it easier to keep knives clean, preventing contaminants such as plaster getting into the mechanism.



Utility knife UK-Z

Durable and well-balanced utility knife, ergonomically designed for the best possible level of safety, comfort and control. Practical screw wheel makes it easy to change blades without having to use tools. Comes with a pack of 10 blades.

- Ergonomic, angled design with pronounced finger grip and narrowing tip that affords excellent grip when measuring and cutting plasterboard in a single stroke.
- Durable zinc housing with a screw wheel that makes it easy to open the knife without using tools.
- The handle contains a practical, spring-loaded blade magazine that holds 10 spare blades (60 mm).
- Few moving parts and magnetic fixings make changing and cleaning blades easy.
- The blade is locked in four stages.

Ref. no.	Model	Blade width	Length	Qty/pack
388010	UK-Z	19 mm	160 mm	6 pcs



Spare Hook Blade Utility Knife

- Made from SK5 carbon steel, hardened to 60-62 HRC.

Ref. no.	Model	Blade width	Length	Fits to	Qty/pack
388620	RB UK H-10	19 mm	48 mm	UK-Z	10 x 10 pcs



Spare Blade Utility Knife

- Made from SK5 carbon steel, hardened to 60-62 HRC.

Ref. no.	Model	Blade width	Length	Fits to	Qty/pack
388520	RB UK-10	19 mm	60 mm	UK-Z	10 x 10 pcs



Spare Blade Utility Knife, 100-pack

- Made from SK5 carbon steel, hardened to 60-62 HRC.

Ref. no.	Model	Blade width	Length	Fits to	Qty/pack
388530	RB UK-100	19 mm	60 mm	UK-Z	4 x 100 pcs

Snap-Off-Knife BK-Z

Robust and reliable snap-off knife, ergonomically designed for maximum safety and comfort. Intelligently designed button makes it easy to feed out and lock the blade with a single hand whilst allowing the blade to be safely fixed in position. Supplied with 1 blade.

- Ergonomic design with pronounced finger grip and narrowing tip that affords excellent grip when measuring and cutting plasterboard in a single stroke.
- Extra long and stable blade support prevents blades from snapping off during work, increasing safety.
- The knife has few moving parts and is easy to open for cleaning and replacing blades.
- One click per blade section - the last blade can also be used.



Ref. no.	Model	Blade width	Length	Qty/pack
389110	BK-Z18	18 mm	180 mm	6 pcs

Registered Community Design No. 000857214-1/6

Saw Knife BK-Z SB

The BK-Z handle combined with the saw blade SB-18 provides this flexible saw. The saw blade is made according to Japanese specifications, it cuts on the backward stroke, meaning that it can be thin and produce a fine, clean sectional cut. The BK-Z handle is ergonomically designed for maximum safety and comfort.

- Smart designed button makes it easy to feed out and lock the blade with a single hand whilst allowing the blade to be safely fixed in position.
- Few parts and easy to open for cleaning and replacing blades.
- The blade is made of SK5 carbon steel, the teeth are hardened to 60-62 HRC.
- The blade is 0.5 mm thick and have 7 teeth per cm.



Ref. no.	Model	Blade width	Length	Qty/pack
389210	BK-Z SB	18 mm	180 mm	10 pcs

Snap-Off-Knife BK-P

Practical snap-off knife made from durable PP plastic and designed for quick and simple blade replacement without using tools. Supplied with 1 blade.

- Built-in snap-off blade tool at the back end of the knife for safe blade snapping.
- Quick and easy blade changes without tools.
- The blade locks in fixed positions as it is fed out.
- Available in two sizes - 9 mm and 18 mm.



Ref. no.	Model	Blade width	Length	Qty/pack
389120	BK-P9	9 mm	128 mm	10 pcs
389130	BK-P18	18 mm	170 mm	10 pcs

Registered Community Design No. 000857214-1/6



Saw Blade Snap-Off Knife

Made according to Japanese specifications, this is a saw blade that cuts on the backward stroke, meaning that it can be thin and produce a fine, clean sectional cut. The saw blade is ideal for your 18 mm snap-off knife.

- Made from SK5 carbon steel.
- The teeth are hardened to 60-62 HRC.
- 0.5 mm thick.
- 7 teeth per cm.
- Fits an 18 mm snap-off knife.

Ref. no.	Model	Blade width	Length	Fits to	Qty/pack
389720	SB-18	18 mm	105 mm	BK-Z	10 x 3 pcs



Glass Scraper

Knife with retractable blade used to easily remove paint and glue from glass and other sensitive surfaces. Supplied with 1 blade.

- Retractable blade for safe storage.
- Quick and easy blade changing.

Ref. no.	Model	Blade width	Length	Qty/pack
389810	GS	19 mm	98 mm	10 pcs



Spare blade, snap-off knife

- Made from SK5 carbon steel, hardened to 60-62 HRC.

Ref. no.	Model	Blade width	Length	Fits to	Qty/pack
389520	RB BK-9 10Stck	9 mm	85 mm	BK-P9	10 x 10 pcs
389620	RB BK-18 10Stck	18 mm	102 mm	BK-P18, BK-Z	10 x 10 pcs



Spare Blade Glass Scraper

- Made from SK5 carbon steel, hardened to 60-62 HRC.

Ref. no.	Model	Blade width	Length	Fits to	Qty/pack
389820	RB GS-10	19 mm	39 mm	GS	10 x 10 pcs

Replaceable striking plate
made of durable nylon
(Available as an accessory).

Santoprene handle for
perfect grip and precision.

Continuous I-beam forged in one
piece for extremely high breaking
capacity and impact resistance and
for better transfer of power into the
object being worked on.

The oval shape of the
handle makes it easier to
remove material.



The entire chisel can be placed flat against the
work surface, meaning that the material can be
removed without damaging the underlying surface.

Blade made from double-
tempered high-quality steel,
perfectly sharpened into a 25°
angle for optimum balance
between sharpness and durability.



SHARP, RELIABLE AND ALWAYS ON HAND.

We decided immediately: our new range of chisels should offer just what professional craftsmen actually need. But we didn't stop there. When we developed our different chisels, we went further than that. The result was not only a series of award-winning chisels that can be likened to handy and durable all-purpose

tools, it was also a brand new series of high quality chisels with a unique design and function. We also decided to develop a brand new type of smart holster that means you can have one or more chisels close by at all times.



EDC CHISELS

When we observed craftsmen at work, it quickly became apparent that they needed a chisel that is easy to carry and can be used for various types of work. This led to Hultafors' EDC chisels - handy chisels with durable blades and sturdy handles that can withstand strong blows from a hammer. The chisels immediately set a new standard and have been awarded both the Red Dot Design Award and the iF Product Design Award.

HDC CHISELS

In our survey, many craftsmen also called for extremely high quality chisels, which were previously absent from the market. We took them at their word and developed the Hultafors HDC Chisel - a unique chisel with a uniform steel construction, forged in a single piece. A highly robust, sharp and durable chisel for craftsmen who want something extra in terms of strength, function and precision.

Chisel HDC

Chisels with perfect precision, sharp, heavy duty, and always close at hand. They are ready for tasks requiring extreme strength and precision. A perfect ground blade, bevelled at 25° for the best possible ratio of sharpness and durability. The entire chisel including the handle can be positioned flat against the surface for more uses. Smart holster made from durable PP plastic for increased accessibility, the holster can easily be attached to a belt or on a button.

- Forged in one piece with an I-beam for extreme durability and to maximize the force transmission down to the work piece.
- Flat contact surface gives an increased number of applications.
- Santoprene handle, optimized for both power and precision.
- Smart holster for increased availability.
- Replaceable nylon striker available as spare part.

Ref. no.	Model	Blade width	Total length	Spare striker	Qty/pack
390263	HDC 20	20 mm	265 mm	390299	2 pcs
390273	HDC 25	25 mm	265 mm	390299	2 pcs
390283	HDC 32	32 mm	265 mm	390299	2 pcs
390293	HDC 40	40 mm	265 mm	390299	2 pcs



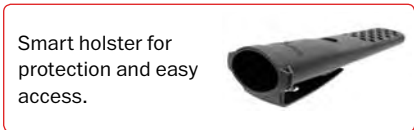

Chisel EDC

An everyday chisel, sharp, reliable and always at hand. Ready for tough precision and all-round use, from adjusting and fitting to prying and demolishing. Perfectly sharpened high-quality Japanese steel blade with heavy-duty handle designed for hard hammer blows. Smart holster with a clip for easy access at all times.

- High-quality Japanese steel blade.
- Rust protected by Electrophoretic deposition (EPD).
- Heavy-duty handle.
- Smart holster for protection and easy access.

Ref. no.	Model	Blade width	Total length	Qty/pack
390013	EDC 6	6 mm	232 mm	5
390023	EDC 10	10 mm	232 mm	5
390033	EDC 12	12 mm	232 mm	5
390043	EDC 16	16 mm	232 mm	5
390053	EDC 18	18 mm	232 mm	5
390063	EDC 20	20 mm	232 mm	5
390073	EDC 25	25 mm	232 mm	5
390083	EDC 32	32 mm	232 mm	5



Chisel Set EDC

Set of 5 chisels in various sizes, gathered in a practical canvas bag. An everyday chisel, sharp, reliable and ready for all-around use, such as adjusting and fitting to prying and demolishing. Perfectly sharpened high-quality Japanese steel blade with heavy-duty handle designed for hard hammer blows.

- Stored in a practical canvas casing.
- High-quality Japanese steel blade.
- Rust protected by Electrophoretic deposition (EPD).
- Heavy-duty handle.

Ref. no.	Model	Blade width	Total length	Qty/pack
390005	EDC S5, 6-25 3	6-10-12-16-25	232 mm	1 pcs



Incannel Gouge IGC

A curved chisel, **sharpened on the inside**, giving a perfect 11 mm radius in one stroke. Sharp, reliable and always at hand when installing lock cases and hinges in wooden doors. The gouge features a high-quality Japanese steel blade, rust protected by Electrophoretic deposition (EPD). Heavy-duty handle designed to withstand repeated hammer blows.

- Perfect when installing locks and hinges.
- High-quality Japanese steel blade.
- Heavy-duty handle.
- Smart holster for easy access at all time.

Ref. no.	Model	Radius	Total length	Qty/pack
390133	IGC d22	11 mm	232 mm	5 pcs



Outcannel Gouge OGC

A curved chisel, **sharpened on the outside**, giving a perfect 8mm radius in one stroke. Sharp, reliable and always at hand, perfect for making cable ditches. The gouge features a high-quality Japanese steel blade with a heavy-duty handle designed to withstand repeated hammer blows.

- Perfect for making cable ditches.
- High-quality Japanese steel blade.
- Heavy-duty handle.
- Smart holster for easy access at all time.

Ref. no.	Model	Radius	Total length	Qty/pack
390123	OGC r8	8 mm	232 mm	5 pcs



Chisel EDC & Craftsmen's knife HVK in a double holster

The Chisel EDC 25 mm and Craftsmen's knife HVK form the perfect combination, in an easily accessible double holster, made from impact-resistant PP plastic, joined by rivets and hardwearing leather. Japanese steel blades with heavy-duty handles designed to withstand repeated hammer blows.

- Easy access and always at hand.
- High-quality Japanese steel blade.
- Heavy-duty handle.
- Impact-resistant PP plastic and hardwearing leather.

Ref. no.	Model	Total length	Qty/pack
391073	EDC 25 & HVK	232/208 mm	5 pcs



Chisel Holder CH

Gather your favourite chisel sizes in a unique 3-chisel holder. Makes it easy to keep your chisels together, especially in the tool bag. Made from hardwearing leather. The holder can also be used on a belt or button. (Chisels not included).

- Keep your chisels together.
- Made from hardwearing leather.

Ref. no.	Model	Qty/pack
390003	CH 3	5 pcs





Hitachi
Hultafornia
Hultafornia



500 mm
19 1/2"

500 mm
19 1/2"

500 mm
19 1/2"

500 mm
19 1/2"

Hultafornia

Hultafornia

Hultafornia

EFFICIENT HANDSAWS.

DEVELOPED TOGETHER WITH PROFESSIONAL CRAFTSMEN

The ultimate saw? We did what we normally do at Hultafors. We talked to the craftsmen and quickly discovered what was needed. A unique combination of powerful design, comfortable grip, razor-sharp blade, power, precision and guaranteed clean cutting without chipping, every time. Then we added our own ideas such as exchangeable blades, a unique blade tip and a stable quick-release blade guard.



HBX HANDSAW – FOR THE PROFESSIONALS

For professionals, a good saw is all about efficiency. The ability to saw fast, straight and safely with a guaranteed neat cut every time. This places extreme demands on the saw. It should be durable without losing sharpness, have a comfortable grip where the force is transferred with every stroke, and be stable and precise without being heavy. That is why the HBX Handsaw has an ergonomic handle, a unique tooth configuration with 3-phase profile, exchangeable blades and a stable quick-lock blade guard. For guaranteed sharpness every time.

HBS HANDSAW – RELIABLE ALL-ROUND SAW

The HBS Handsaw is a reliable all-round saw in a somewhat simpler design. It shares a number of functions with the HBX model. For example, it has an equally thick blade (1 mm) for extra stability and precision. It also features the same unique blade tip designed to facilitate when you start cutting in the middle of a board. It also has a comfortable lightweight handle with a 45° and 90° angle guide. A really sharp challenger in the segment.

HANDSAWS

WITH PERFECT GRIP FOR POWER AND PRECISION

A good saw is all about efficiency. The ability to saw fast, straight and safely with a guaranteed neat cut.

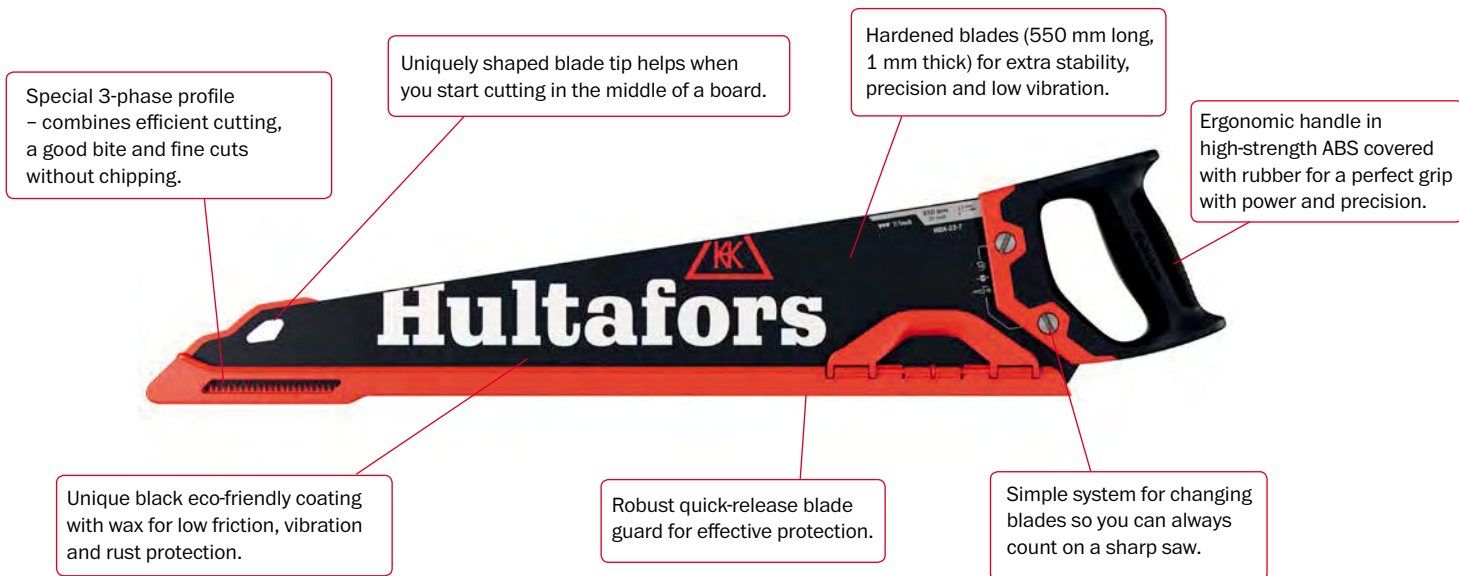

EXCHANGEABLE BLADES

The HBX handsaw has a smart and simple system that enables you to quickly switch blades. Undo the two screws, pull out the blade and insert a new one, tighten the screws. Done!

BLADE ASSORTMENT

7" - coarse cuts, timber, fresh and treated lumber.

9" - medium-coarse cuts, medium-coarse wood.

11" - fine cuts, fine wood, laminate.





HANSAW HBX

Handsaw developed for the modern craftsmen in close cooperation with professional users. Hultafors unique teeth's with 3-phase grinding combines efficiency and a good bite with nice straight cuts without chipping. The 1mm thick steel blade with a unique eco-friendly wax coating gives less friction and power-consuming side vibrations. The durable three-component handle has a comfortable ergonomic grip and 45° and 90° angle guide. The handle is mounted to the blade with a stable safety screw which enables changing blade in a simple and reliable way. The narrow blade tip facilitates access in narrow spaces and when to start cutting in the middle of a board.

- Unique teeth's with 3-phase grinding combines efficiency and a long life time.
- Eco-friendly wax coating gives rust protection, less friction and power-consuming side vibrations.
- Reliable, easy and secure system for changing the blade.
- Ergonomic and durable ABS handle
- A unique and durable blade protection with quick release function.

Ref.No.	Model	Blade length	Blade length	Teeth/ inch	Spare blade	Qty/pack
590703	HBX-22-7	550 mm	22 inch	7	590713	4 pcs
590704	HBX-22-7	550 mm	22 inch	7	590713	10 pcs
590705	HBX-22-7	550 mm	22 inch	7	590713	24 pcs
590903	HBX-22-9	550 mm	22 inch	9	590913	4 pcs
590904	HBX-22-9	550 mm	22 inch	9	590913	10 pcs
590905	HBX-22-9	550 mm	22 inch	9	590913	24 pcs
591103	HBX-22-11	550 mm	22 inch	11	591113	4 pcs
591104	HBX-22-11	550 mm	22 inch	11	591113	10 pcs
591105	HBX-22-11	550 mm	22 inch	11	591113	24 pcs

SAWBLADE HBX

The HBX sawblade is available with three tooth sizes: 7, 9, 11 teeth/inch, for various applications. Hultafors unique teeth's with 3-phase grinding combines efficiency and a good bite with nice straight cuts without chipping. The 1mm thick steel blade with a unique eco-friendly wax coating gives less friction and power-consuming side vibrations.

- Unique teeth's with 3-phase grinding combines efficiency and a long life time.
- The 1mm thick steel blade gives less friction and power-consuming side vibrations.
- Eco-friendly wax coating with rust protection and less friction



Ref.No.	Model	Blade length	Blade length	Teeth/ inch	Spare blade	Qty/pack
590713	BX-22-7	550 mm	22 inch	7	-	4 pcs
590913	BX-22-9	550 mm	22 inch	9	-	4 pcs
591113	BX-22-11	550 mm	22 inch	11	-	4 pcs

HANSAW HBS

A standard saw for universal use with a fiberglass reinforced handle, rubber grip and 45° and 90° angle guide. The handle is mounted with screws for increased durability. The saw blade is made of 1mm thick steel which gives extra stability, precision and low vibrations. Hardened teeth with standard 2-phase grinding for efficiency and a long life time. The narrow blade tip facilitates access in narrow spaces and when to start cutting in the middle of a board.

- Blade of 1mm thick steel provides extra stability, precision and low vibration.
- Fiberglass reinforced handle with rubber grip.
- Basic but durable blade protection included.
- Handsaw HBS is available in a 10-pack or 45-pack display box.



Ref.No.	Model	Blade length	Blade length	Teeth/ inch	Qty/pack
590724	HBS-22-7	550 mm	22 inch	7	10 pcs
590725	HBS-22-7	550 mm	22 inch	7	45 pcs



CLAMPS TO RELY ON.

Craftsmen know what a difference it makes when they are truly able to rely on their tools. This is especially true for clamps, which often have to be put into place quickly to hold together, support or stabilise a project. This is exactly what Hultafors' range of quick clamps and screw clamps are for. Easy to use, ergonomic and durable clamps that guarantee long-lasting reliable clamping forces. The fundamental qualities that characterise all Hultafors tools.



EASY TO USE QCX/QC QUICK CLAMPS

Quick and handy or extreme clamping force? If you ask professional craftsmen about quick clamps, they usually answer that the clamps must be quick to put into place and have enough clamping force to do the job well. That is why we have prioritised a neat, compact and ergonomic design using durable materials. This ensures that Hultafors' Quick Clamps are easy to use and effective with enough clamping force to work securely.

RELIABLE CF/CFP/CM SCREW CLAMPS

Sturdy, neat and good grip for easy use with substantial clamping force. Hultafors' of screw clamps have been developed to simplify the work of professional craftsmen. The powerful CM model is made from impact resistant malleable castings. The rail is grooved on both sides to minimise the risk of the leg sliding when the clamp is being attached. The PFC screw clamp with its chrome coated die-cast rail has a pivoting handle to provide greater force when tightening and loosening.

QUICK CLAMPS

QUICK, EASY TO USE AND DURABLE

Compact and ergonomic design using durable materials with enough clamping force to work securely.

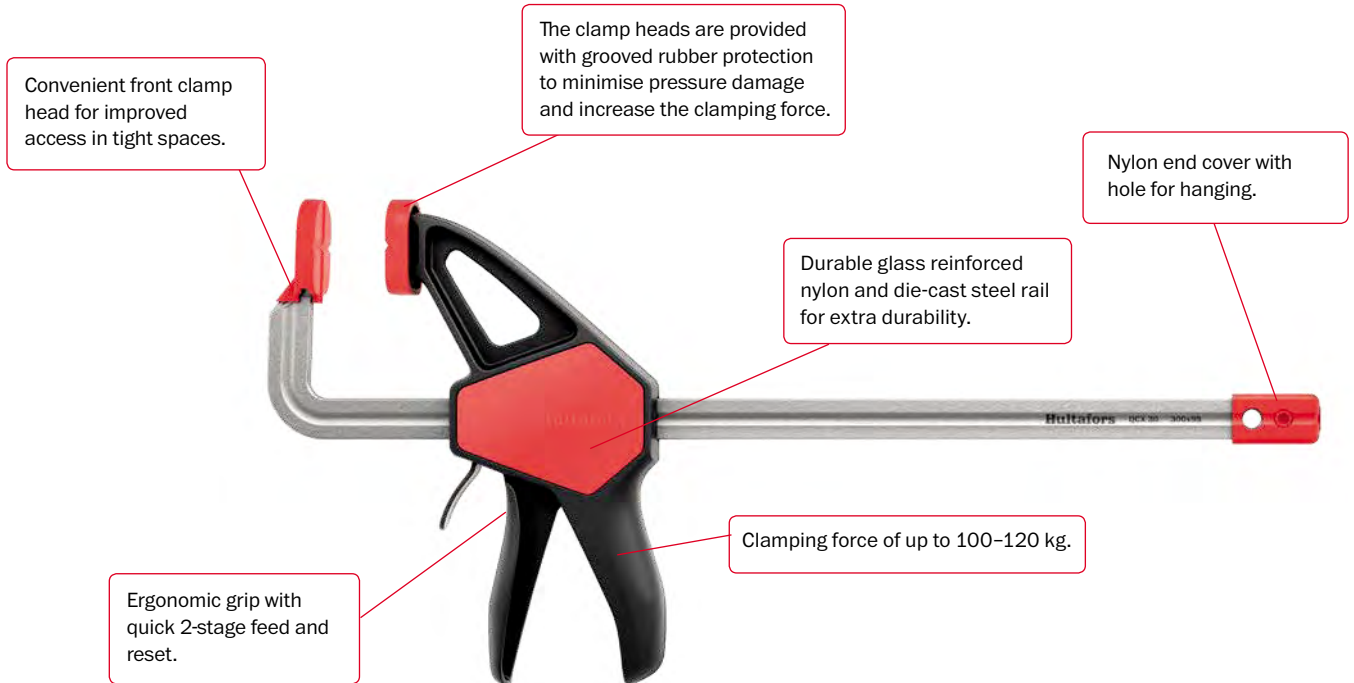

QUICK CLAMP QCX

Compact one-hand clamp made of fiberglass-reinforced nylon. Steel rail forged in one piece, with a slim front jaw for increased access in tight places. Pressure plates with tracked rubber pads to protect the surface and provide increased clamping force. Design with focus on compact and slim operation.

- Slim front jaw for increased access in narrow places.
- Quick and easy clamping operations.
- Clamping force up to 100-120 kg.
- End protection made of nylon.



Ref.No.	Model	Clamping cap.	Throat depth	Rail Dim.	Weight	Qty/pack
521153	QCX 15	150 mm	95 mm	20 x 6 mm	650 g	2 pcs
521303	QCX 30	300 mm	95 mm	20 x 6 mm	800 g	2 pcs
521453	QCX 45	450 mm	95 mm	20 x 6 mm	920 g	2 pcs
521603	QCX 60	600 mm	95 mm	20 x 6 mm	1050 g	2 pcs

QUICK CLAMP QC

Compact one-hand clamp made of fiberglass-reinforced nylon. Steel rail forged in one piece, with a slim front jaw for increased access in tight places. Pressure plates with tracked rubber pads to protect the surface and provide increased clamping force. Design with focus on compact and slim operation.

- Slim front jaw for increased access in narrow places.
- Quick and easy clamping operations.
- Clamping force up to 60-70 kg.
- End protection made of nylon.



Ref.No.	Model	Clamping cap.	Throat depth	Rail Dim.	Weight	Qty/pack
520153	QC 15	150 mm	75 mm	20 x 6 mm	600 g	2 pcs
520303	QC 30	300 mm	75 mm	20 x 6 mm	710 g	2 pcs
520453	QC 45	450 mm	75 mm	20 x 6 mm	850 g	2 pcs
520603	QC 60	600 mm	75 mm	20 x 6 mm	980 g	2 pcs

RATCHET CLAMP RC

One-hand clamp with ratchet function allows different clamping forces. Fiberglass reinforced nylon with 2-component handles and plastic pressure plates.

- Swivel pressure plates.
- Ratchet function.
- Friction grip.



Ref.No.	Model	Clamping cap.	Throat depth	Weight	Qty/pack
525383	RC-38	38 mm	32 mm	80 g	2 pcs
525583	RC-58	38 mm	55 mm	200 g	2 pcs

SCREW CLAMPS

Sturdy, neat and with good grip for easy use with substantial clamping force. Hultafors' screw clamps have been developed to simplify the work of professional craftsmen.

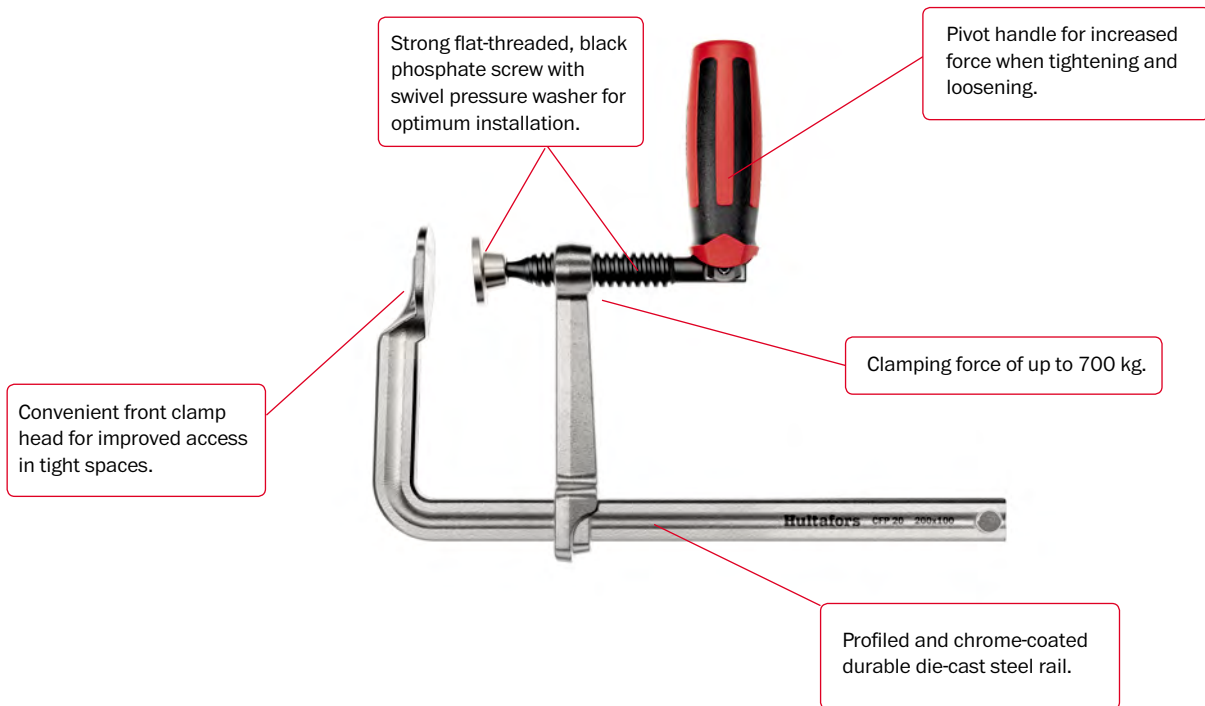

SCREW CLAMP CFP, pivoted handle

Steel rail forged in one piece, profiled, nickel and chrome plated. Pivoting handle for increased clamping pressure. Slim front anvil for increased access in narrow places. Strong flat threaded, black phosphate screw with tilted pressure plate.

- Pivoting handle for increased clamping pressure.
- Slim front anvil for increased access in narrow places.
- Tilting or floating pressure plate.
- Clamping force up to 700kg.



Ref.No.	Model	Clamping cap.	Throat depth	Rail Dim.	Weight	Qty/pack
522203	CFP 20	200 mm	100 mm	19,5 x 9,5 mm	1050 g	2 pcs
522253	CFP 25	250 mm	120 mm	22 x 10,5 mm	1400 g	2 pcs
522303	CFP 30	300 mm	14 mm	25 x 12 mm	1950 g	2 pcs
522403	CFP 40	400 mm	175 mm	27 x 13 mm	2600 g	2 pcs

SCREW CLAMP CF

Steel rail forged in one piece, profiled, nickel and chrome plated with wooden handle. Slim front anvil for increased access in narrow places. Strong flat threaded, black dyeing screw with tilted pressure plate.

- Slim front anvil for increased access in narrow places.
- Tilting or floating pressure plate.
- Clamping force up to 670kg.



Ref.No.	Model	Clamping cap.	Throat depth	Rail Dim.	Weight	Qty/pack
523103	CF 10	100 mm	50 mm	11,5 x 5,7 mm	200 g	2 pcs
523123	CF 12	120 mm	60 mm	13,5 x 6,5 mm	300 g	2 pcs
523163	CF 16	160 mm	80 mm	16 x 7,5 mm	500 g	2 pcs
523203	CF 20	200 mm	100 mm	19,5 x 9,5 mm	900 g	2 pcs
523253	CF 25	250 mm	120 mm	22 x 10,5 mm	1300 g	2 pcs
523303	CF 30	300 mm	140 mm	25 x 12 mm	1900 g	2 pcs
523403	CF 40	400 mm	120 mm	22 x 10,5 mm	1500 g	2 pcs
523503	CF 50	500 mm	120 mm	22 x 10,5 mm	1700 g	2 pcs

SCREW CLAMP CM

A strong clamp with jaws of impact resistant malleable castings and a wooden handle. Profiled rail of nickel and chrome plated steel with grooves on both sides to prevent the slider from slipping at fixation. Strong flat threaded, black dyeing screw with tilted pressure plate and plastic protective caps.

- Profiled and ribbed steel rail.
- Anvil with plastic protection caps.
- Tilting or floating pressure plate.
- Jaw with support foot.
- Clamping force up to 500 kg.



Ref.No.	Model	Clamping cap.	Throat depth	Rail Dim.	Weight	Qty/pack
524123	CM 12-6	120 mm	60 mm	20 x 5 mm	450 g	2 pcs
524163	CM 16-8	160 mm	80 mm	25 x 6 mm	750 g	2 pcs
524203	CM 20-10	200 mm	100 mm	27 x 7 mm	1150 g	2 pcs
524253	CM 25-8	250 mm	80 mm	25 x 6 mm	850 g	2 pcs
524263	CM 25-12	250 mm	120 mm	29 x 9 mm	1500 g	2 pcs
524303	CM 30-12	300 mm	120 mm	29 x 9 mm	1600 g	2 pcs
524313	CM 30-14	300 mm	140 mm	32 x 10 mm	2050 g	2 pcs
524403	CM 40-14	400 mm	140 mm	32 x 10 mm	2250 g	2 pcs
524413	CM 40-17	400 mm	175 mm	32 x 10 mm	2350 g	2 pcs
524503	CM 50-12	500 mm	120 mm	29 x 9 mm	1950 g	2 pcs



reddot design award
best of the best 2012

Adjustable wrecking bar. We have a wrecking bar with an articulated claw that is adjustable to nine different positions. Thanks to its gear ring, it can handle the same stresses as a standard wrecking bar. The adjustable wrecking bar saves you time and is kind to your body.

Optimised function. Our best crowbars/wrecking bars are made from high-alloy boron steel. They have wide, polished contact surfaces and thin ends for better access and reduced risk of leaving marks. The claw is ground to optimise nail removal.

Aluminium pry bars. We produce a number of pry bars in tough, durable aluminium that we have specifically developed for workshop use. You can use them to adjust wheel settings, test wheel bearings and fit body parts.

Choose the right pry bar! We produce a range of different bars, including levers, crowbars/wrecking bars and pry bars, in several different designs and materials. You will always be able to find one that satisfies your requirements. Steel is nearly three times as strong as aluminium, although aluminium weighs only 1/3 as much as steel.

DEMOLISH WITH QUALITY.

When working on ripping out windows or room furnishings, it is important that you choose a tool that is as easy to handle as possible. In such instances, a wrecking bar is exactly what you need.

POWER, WEIGHT AND A WILL OF STEEL

Steel is almost three times as heavy as aluminium, but it is also three times as strong. When doing work where weight and power is critical to achieving a good result, steel is the obvious choice.

LIGHT, RESILIENT AND KIND TO SURFACES

Aluminium weighs only 1/3 as much as steel. It is easier to work with and gentler on your body, particularly when working at shoulder height or above. Aluminium is also considerably

gentler on the materials you work with. It doesn't rust, is more resistant to cold and is much more flexible. An aluminium tool can be "bent" about three times as much as a steel tool without being deformed. This means that aluminium pry bars are ideal for fitting and adjusting in various applications in the engineering industry.

BE KIND TO YOUR BODY!

To help you steer clear of any injuries, we've come up with a few tips. Always work with a straight back, but try to avoid working with straight arms. You should also avoid working with bent wrists. The best thing to do is to try and change your work posture as often as you can. Also try to avoid getting into too many situations that involve jerking and wrenching.



Wrecking Bar Steel Adjustable 209 SB

Wrecking bar manufactured in high quality steel with ergonomic rubber-clad handle. Articulated claw, adjustable to nine different positions. Wide, ground contact surfaces and thin ends make it easy to use and reduce the risk of leaving marks. The claw is optimised for pulling out nails. The curved section at the chisel makes space for the hand and minimizes the risk of crushing damage.

- Adjustable claw in nine steps for best working position.
- Wide, ground contact surfaces and thin ends make it easy to use in narrow spaces and reduce the risk of leaving marks.
- Optimised claw for pulling out nails.
- Secure strap function.



Ref. no.	Model	Length	Weight	Qty/pack
824115	209 SB/25"	640 mm	1730 g	2 pcs

Registered Community Design No. 001307557-1/3

Wrecking Bar Steel Adjustable 109 SB

Wrecking bar made from hardened, high-alloy boron steel. Articulated claw, adjustable to nine different positions. Thanks to its gear ring, the bar can handle the same stresses as a standard wrecking bar.

- Made from hardened, high-alloy boron steel.
- Wide, ground contact surfaces and thin ends make it easy to use in narrow spaces and reduce the risk of leaving marks.
- The claw is optimised for pulling out nails and can be set in nine different positions for increased accessibility and better work posture.



Ref. no.	Model	Length	Weight	Qty/pack
824015	109 SB/26"	660 mm	1700 g	2 pcs
824016	Spare screw	14 mm		1 pcs

Wrecking Bar Steel 109

Wrecking bar made from hardened, high-alloy boron steel. Wide, ground contact surfaces and thin ends make it easy to use in narrow spaces and reduce the risk of leaving marks.

- Made from hardened, high-alloy boron steel.
- Wide, ground contact surfaces and thin ends make it easy to use in narrow spaces and reduce the risk of leaving marks.
- The claw is optimised for pulling out nails.



Ref. no.	Model	Length	Weight	Qty/pack
824009	109/12"	300 mm	450 g	2 pcs
824010	109/20"	500 mm	1100 g	2 pcs
824011	109/25"	625 mm	1450 g	2 pcs
824012	109/28"	710 mm	1950 g	2 pcs
824013	109/36"	900 mm	2850 g	2 pcs

Wrecking bar steel 109/25" TD

Wrecking bar made from hardened, high quality steel. Wide, ground contact surfaces and thin ends make it easy to use in narrow spaces and reduce the risk of leaving marks. It has three different functions that are optimised for pulling out nails.

- The claw and chisel are optimised for pulling out nails.
- Made from hardened, high quality steel.
- Wide, ground contact surfaces and thin ends make it easy to use in narrow spaces and reduce the risk of leaving marks.



Ref. no.	Model	Length	Weight	Qty/pack
824021	109/25"TD	640 mm	1480 g	2 pcs

Wrecking Bar Steel 107

Steel wrecking bar made to a slightly simpler design.



Ref. no.	Model	Length	Weight	Qty/pack
824005	107/16"	400 mm	750 g	2 pcs
824001	107/21"	525 mm	900 g	2 pcs
824002	107/24"	600 mm	1550 g	2 pcs
824003	107/27"	675 mm	1750 g	2 pcs
824004	107/30"	750 mm	2000 g	2 pcs

Wrecking Bar Steel 108

A small, versatile steel wrecking bar that can be used for pulling out nails and for breaking, scraping and lifting.

- Has three different functions for pulling out nails.
- Can be used for breaking, scraping and lifting.



Ref. no.	Model	Length	Weight	Qty/pack
827013	108/15"	380 mm	650 g	2 pcs
827043	108/21"	531 mm	860 g	2 pcs

Wrecking Bar Steel 108 MINI

A small, useful steel 7.5" wrecking bar that can be used to pull small nails, remove wood strips or to open cans.

- Has three different functions for pulling out nails.
- Thin contact surfaces make it easy to use in narrow spaces.



Ref. no.	Model	Length	Weight	Qty/pack
827023	108 Mini	190 mm	77 g	5 pcs

Wrecking Bar Steel 101

A small wrecking bar with a claw at one end and a straight chisel at the other. Used as an all-round tool in car workshops and for assembly work in the mechanical industry.

- Has underside support to provide extra strength.



Ref. no.	Model	Length	Weight	Qty/pack
824000	101 B	330 mm	550 g	2 pcs

Pinch Bar Steel 207

Pinch bar made from 6-square high quality steel. A wide and thin chisel make it easy to use in narrow spaces. The long and cone shaped tip is used for e.g. the mating of flange with bolt holes. The cone tip facilitates the installation of O-rings.

- A wide and thin chisel to increase accessibility.
- Long and evenly grinded cone shaped tip.
- Unpainted cone and chisel to avoid discoloration.



Ref. no.	Model	Length	Weight	Qty/pack
824031	207/400	400 mm	580 g	2 st
824032	207/500	500 mm	760 g	2 st
824033	207/600	600 mm	926 g	2 st

Pry Bar Steel SP

Steel pry bar that can handle high loads and work on stony and hard ground.

- The bar is made from high-grade steel to ensure the best possible level of user safety.
- Model SP 7 PIK is 1500 mm and spike sharpened.



Ref. no.	Model	Length	Weight	Qty/pack
826003	SP 5	1200 mm	5000 g	1 pcs
826004	SP 6	1350 mm	6000 g	1 pcs
826005	SP 7	1500 mm	7000 g	1 pcs
826006	SP 8	1650 mm	8000 g	1 pcs
826055	SP 7 PIK	1500 mm	7000 g	1 pcs

Pry Bar Steel HHS

Steel pry bar for work on stony and hard ground.



Ref. no.	Model	Length	Weight	Qty/pack
865501	HHSP 1500	1500 mm	6800 g	1 pcs

Pry Bar Steel BLS

Steel pry bar with a steel ball welded onto the handle.

- Made from high-grade steel to ensure the best possible level of user safety.



Ref. no.	Model	Length	Weight	Qty/pack
843020	BLS 1150	1150 mm	6000 g	1 pcs



Pry Bar Aluminium

Aluminium weighs only 1/3 as much as steel, which means that tools made from it are lighter and easier to work with. Used for applications such as prizing items onto truck platforms and ripping up formwork.

- Aluminium pry bars are lighter and easier to work with, especially when working at shoulder height.
- Gentler to the material you work with.
- An aluminium tool does not rust, has better resistance to cold and is also more flexible than steel tools.
- It can be bent about three times as much as a steel tool without being deformed.

Ref. no.	Model	Length	Weight	Qty/pack
841000	B 1200	1200 mm	2100 g	1 pcs
841002	B 1500	1500 mm	2800 g	1 pcs



Pry Bar Aluminium, With Steel Point

Aluminium pry bar is lighter and easier to work with, especially when working at shoulder height. The steel point is required if the bar is to be used to strike and cut.

- The steel point is used to strike and cut.
- An aluminium tool does not rust, has better resistance to cold and is also more flexible than steel tools.
- It can be bent about three times as much as a steel tool without being deformed.

Ref. no.	Model	Length	Weight	Qty/pack
841001	B 1200 S	1200 mm	2700 g	1 pcs
841003	B 1500 S	1500 mm	3600 g	1 pcs
841006*	B Steel point	-	1100 g	1 pcs

*Spare steel point



Pry Bar Aluminium, with Steel Point

An aluminium pry bar that also can endure breaking work. The steel point makes it able to withstand high breaking loads.

- Manufactured in "Aerospace aluminium" for high strength and less flexing.
- Aluminium pry bars are lighter and easier to work with, especially when working at shoulder height.
- An aluminium tool does not rust, and has better resistance to cold.
- It can be bent about three times as much as a steel tool without being deformed.

Ref. no.	Model	Length	Weight	Qty/pack
841014	A 1500 SR	1500 mm	3200 g	1 pcs



Pry Bar Aluminium, with Pinch Point

Able to withstand high breaking loads. The bent point prevents you trapping your fingers close to the floor. Can be used for demolition of moulds.

- Manufactured in "Aerospace aluminium" for high strength and less flexing.
- Aluminium pry bars are lighter and easier to work with, especially when working at shoulder height.
- An aluminium tool does not rust, and has a better resistance to cold.
- It can be bent about three times as much as a steel tool without being deformed.

Ref. no.	Model	Length	Weight	Qty/pack
841024	A 1500 SB	1500 mm	3200 g	1 pcs

Bending Bar Aluminium

Aluminium bending bar. Used as a practical tool within industry. Originally developed to remove ice from wheels and to test the brakes on train carriages.

- Aluminium is lighter and easier to work with.
- Gentler to the material you work with.
- An aluminium tool does not rust and can better withstand cold conditions.

Ref. no.	Model	Length	Weight	Qty/pack
841021	H 700	680 mm	700 g	2 pcs

Bending Bar Aluminium

Aluminium bending bar with bent tip. Originally produced to test wheel bearings on cars, but also used by locksmiths to adjust door fittings.

- Aluminium is lighter and easier to work with.
- Gentler to the material you work with.
- An aluminium tool does not rust and can better withstand cold conditions.

Ref. no.	Model	Length	Weight	Qty/pack
841022	H 700 B	680 mm	700 g	2 pcs

Bending Bar Aluminium

Aluminium bending bar with bent tip. This is a shorter version of the H700 pry bar, which can fit in a toolbox. Usually used in car workshops to adjust wheel alignment.

- Aluminium is lighter and easier to work with.
- Gentler to the material you work with.
- An aluminium tool does not rust and can better withstand cold conditions.

Ref. no.	Model	Length	Weight	Qty/pack
841020	H 480 B	480 mm	500 g	2 pcs

Bending Bar Aluminium

Aluminium bending bar with cone shaped tip. Used to fit flanges together with bolt holes and to gently bend copper pipes. A very widely used tool for fitting body parts.

- Aluminium is lighter and easier to work with.
- Gentler to the material you work with.
- An aluminium tool does not rust and can better withstand cold conditions.

Ref. no.	Model	Length	Weight	Qty/pack
841010	F 430	430 mm	400 g	2 pcs

Bending Bar Aluminium

Aluminium bending bar with cone shaped tip. Used to fit flanges together with bolt holes and to gently bend copper pipes. A very widely used tool for fitting body parts.

- Aluminium is lighter and easier to work with.
- Gentler to the material you work with.
- An aluminium tool does not rust and can better withstand cold conditions.

Ref. no.	Model	Length	Weight	Qty/pack
841011	F 820	820 mm	1700 g	2 pcs



Durable materials. The Flexi Tool Bags and Tool Bag/Backpacks feature robust rubber-clad aluminium handles and hard-wearing bottoms in rubber-plastic, reducing the risk of leaving marks on the floor and preventing the tool bag from sliding around in the car.

Smart tool carrying. With the pioneering Flexi Tool Bag/Backpack, you can carry your essential tools on your back – leaving your hands free for other things or for safely climbing a ladder.

XTR – the ultimate Toolbelt. The new advanced XTR Toolbelt takes mobile tool carrying to yet another level. It features a unique pocket attachment system that allows you to place the durable leather pouches exactly where you want them.

Easy access to your tools. Count on superior overview and access to your tools. All Flexi Tool Bags and Tool Bag/Backpacks feature tool loops, compartments, elastic cords, multi-purpose pockets and dedicated holders for your cordless drill.

GEAR UP FOR EXTREME MOBILITY.

THE NEW GENERATION TOOL CARRIERS FROM SNICKERS WORKWEAR

You know the drill. Always on the move. From the car to the workplace, from one spot to another. And when you need that special tool you need it now. Simply put, you want easy access to your tools at all times. That's why we offer the new generation of tool bags and belts from our sister brand Snickers

Workwear. They are experts in the field and have more than 30 years of experience in mobile tool carrying. No surprise their new range is designed with cutting-edge ergonomics and advanced functionality for extreme mobility at work.



Multi-purpose pocket with protective flap.

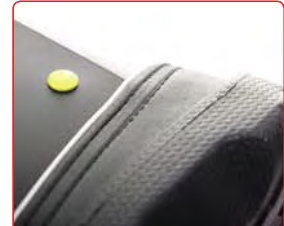

Hard-wearing bottom made of rubber-plastic reduces the risk of leaving marks on the floor.

Ergonomically curved design for added carrying comfort.



Foldable, rubber-clad aluminium handle. Locks in upright position for steady carrying.

Wide range of tool compartments, including special holders for your cordless drills.



Flexi Tool Bag 30 L

Cutting-edge tool bag with advanced ergonomic design and outstanding functionality, giving you easy access to your tools at all times. Hardwearing and flexible with a range of tool compartments, keeping your gear in place when on the move.

- Ergonomically curved design and outside padding for added comfort and convenience when carrying at the side of your body.
- Foldable, rubber-clad aluminium handle – folds down for superior overview and access to your tools, locks in upright position for steady carrying.
- Durable tool loops and compartments, including dedicated holders for cordless drills, and an easy-access, multi-purpose pocket with protective flap.
- Hard-wearing bottom in rubber-plastic, reduces the risk of leaving marks on the floor and prevents the tool bag from sliding around in the car.
- Ergonomic and padded shoulder strap for superior carrying comfort, while its anti-slip material keeps the tool bag from sliding off your shoulder.
- Material: Hard-wearing EVA base and robust PE-boards with textile interior (polyamid).

Ref. no.	Model	Weight	Dimensions (LxWxH)	Qty/pack
9822	Flexi 30	3.2 kg	530 x 280 x 350 mm	1 pcs



Flexi Tool Bag 15 L



The optimal tool bag for your essential tools when on the move. Advanced ergonomic design for convenient carrying and foldable handle for easy access at all times. Hardwearing and compact, yet with a range of practical tool compartments.

- Ergonomically curved design and outside padding for added comfort and convenience when carrying at the side of your body.
- Foldable, rubber-clad aluminium handle – folds down for superior overview and access to your tools, locks in upright position for steady carrying.
- Durable tool loops and compartments, including dedicated holder for a cordless drill, and an easy-access, multi-purpose pocket with protective flap.
- Hard-wearing bottom in rubber-plastic, reduces the risk of leaving marks on the floor and prevents the tool bag from sliding around in the car.
- Ergonomic and padded shoulder strap for superior carrying comfort, while its anti-slip material keeps the tool bag from sliding off your shoulder.
- Material: Hard-wearing EVA base and robust PE-boards with textile interior (polyamid).

Ref. no.	Model	Weight	Dimensions (LxWxH)	Qty/pack
9820	Flexi 15	2.1 kg	345 x 200 x 320 mm	1 pcs



Flexi Tool Bag/Backpack 23 L



Revolutionary tool bag/backpack for no-hands carrying. Bring your tools on your back and free the hands for other things or to safely climb a ladder. Rely on advanced ergonomic design and cutting-edge functionality – for extreme mobility at work.

- Superior carrying comfort thanks to ergonomic design with padded back and adjustable padded shoulder straps.
- Foldable, rubber-clad aluminium handle – folds down for superior overview and access to your tools, locks in upright position for steady carrying.
- Durable tool loops and compartments, including dedicated holder for a cordless drill, and an easy-access, multi-purpose pocket with protective flap.
- Hard-wearing bottom in rubber-plastic, reduces the risk of leaving marks on the floor and prevents the tool bag from sliding around in the car.
- Elastic cords inside for easy storage and quick access to spirit levels, long drills and longer tools.
- Material: Hard-wearing EVA base and robust PE-boards with textile interior (polyamid).

Ref. no.	Model	Weight	Dimensions (LxWxH)	Qty/pack
9812	Flexi 23	2.7 kg	415 x 230 x 450 mm	1 pcs



Flexi Tool Bag/Backpack 19 L



The ultimate way to bring your essential tools. Compact tool bag/backpack with advanced ergonomic design, leaving your hands free for other things or to safely climb a ladder. Hardwearing and flexible with a range of practical tool compartments.

- Superior carrying comfort thanks to ergonomic design with padded back and adjustable padded shoulder straps.
- Foldable, rubber-clad aluminium handle – folds down for superior overview and access to your tools, locks in upright position for steady carrying.
- Durable tool loops and compartments, including dedicated holder for a cordless drill, and an easy-access, multi-purpose pocket with protective flap.
- Hard-wearing bottom in rubber-plastic, reduces the risk of leaving marks on the floor and prevents the tool bag from sliding around in the car.
- Elastic cords inside for easy storage and quick access to spirit levels, long drills and longer tools.
- Material: Hard-wearing EVA base and robust PE-boards with textile interior (polyamid).

Ref. no.	Model	Weight	Dimensions (LxWxH)	Qty/pack
9810	Flexi 19	2.3 kg	345 x 200 x 430 mm	1 pcs



Hammer Holder



Advanced, hard-wearing hammer holder with ergonomic design. Angled for easy access and comfortable positioning of the hammer against the leg.

- Ergonomically angled design prevents the hammer-handle from hitting your leg when walking and getting in the way when bending down on your knees.
- Easy to attach to Snickers tool fasteners, trousers, belts, Toolvest and Flexi™Pocket system.
- Angled slightly away from your body for easy access to the hammer.
- Accommodates most hammers in the market.
- Made in a hard-wearing yet flexible material that will not scrape delicate surfaces.
- Material: 100% Thermoplastic Elastomer (TPE).

Ref. no.	Model	Qty/pack
9716	Hammer Holder	1 pcs
9736	Hammer Holder	10 pcs



Alt 1. Carpenter's Tool Pouch



Alt 2. Electrician's Tool Pouch



XTR Carpenter's Toolbelt, XTR Electrician's Toolbelt

Gear up with the ultimate toolbelt. Count on advanced ergonomic design, padded braces and a flexible attachment system that includes hardwearing leather pouches and a special carpenter or electrician's tool pouch.

- Cordura® reinforced belt in advanced ergonomic design with an innovative and flexible pouch attachment system.
- Adjustable and removable braces with shoulder padding reduce the weight on your hips for enhanced ergonomics and comfort.
- 9770: Special carpenter's leather tool pouch with compartments and loops, including a hammer holder, knife attachment buttons and pen compartment.
- 9780: Special electrician's leather tool pouch with compartments and loops for screwdrivers, pliers, utility knife, voltmeter and hammer.
- Two durable leather nail & screw pouches with angled design and wide openings for easy access
- Robust and innovative aluminium buckle designed for easy opening and closing.
- Material: Belt in 100% Nylon, 100% Polyamide and 100% Cordura®. Leather pouches.

Ref. no.	Model	Size	Qty/pack
9770	XTR Carpenter's Toolbelt	Small 44-48 Medium 48-54 Large 54-60	1 pcs
9780	XTR Electrician's Toolbelt	Small 44-48 Medium 48-54 Large 54-60	1 pcs
9775	Carpenter's Tool Pouch	One size	1 pcs
9785	Electrician's Tool Pouch	One size	1 pcs
9795	Nail & Screw Pouches	One size	2 pcs
9790	XTR Toolbelt	Small 44-48 Medium 48-54 Large 54-60	1 pcs
9792	Braces	One size	1 pcs



Alt 1. Carpenter's Tool Pouch



Alt 2. Electrician's Tool Pouch



Carpenter's Toolbelt, Electrician's Toolbelt

Keep it all in place with this steady toolbelt. Designed with reinforced functionality and a flexible attachment system that includes hardwearing leather pouches and a special carpenter or electrician's tool pouch.

- Reinforced belt in curved design with an innovative and flexible pouch attachment system.
- Soft padding for enhanced working comfort.
- 9771: Special carpenter's leather tool pouch with compartments and loops, including a hammer holder, knife attachment buttons and pen compartment.
- 9781: Special electrician's leather tool pouch with compartments and loops for screwdrivers, pliers, utility knife, voltmeter and hammer.
- Two durable leather nail & screw pouches with angled design and wide openings for easy access.
- Robust and innovative aluminium buckle designed for easy opening and closing.
- Material: Belt in 100% Nylon, 100% Polyamide. Leather pouches.

Ref. no.	Model	Size	Qty/pack
9771	Carpenter's Toolbelt	Small 44-48 Medium 48-54 Large 54-60	1 pcs
9781	Electrician's Toolbelt	Small 44-48 Medium 48-54 Large 54-60	1 pcs
9775	Carpenter's Tool Pouch	One size	1 pcs
9785	Electrician's Tool Pouch	One size	1 pcs
9795	Nail & Screw Pouches	One size	2 pcs
9791	Toolbelt	Small 44-48 Medium 48-54 Large 54-60	1 pcs

PUT YOUR COMPANY IN FOCUS.



Hultafors can offer advertising print on a number of different models of folding rule, pencil and knife. In the case of folding rules, the print may be located on the section and/or side. Note that the printed surface may differ from model to model. Folding rules with advertising print are supplied as standard in packs of 10 (plastic foil) without an EAN code on the rule.

COLOURS

Hultafors can offer printing in the following standard colours as per the Pantone Scale (PMS). For an additional charge, Hultafors can offer a further 600 shades as per the PMS Scale. We will be happy to provide a quote for any special colours that cannot be mixed by Hultafors and must be ordered from an external supplier. Note that there may occasionally be minor colour variations in relation to the PMS Scale.

PRINT AREA KEY, FOLDING RULES

RE = Print side. The rule has a standard scale on the end sections, restricting the print area to the side of the rule (section printing not available). The print area is suitable for logos, company names or other text and images.

FÖ = Upper field section print + print side. The upper half of both end sections of the rule are available as a print area. This is suitable for a company name, telephone and fax numbers or a short slogan. Can be combined with print along the side of the rule.

MF = Middle field section print + print side. Comparable with FÖ (upper field), but the print area is located in the centre of the end sections for unhindered use of the scale on both sides of the section. Can be combined with print along the side of the rule.

PROOFING

Hultafors imposes the following requirements in respect of documentation for proofing:

- Images in the form of logotype or other vectorised image must be enclosed with the proof order as an open EPS file, or as a paper document of at least laser quality printed 50% larger than the print. Hultafors will be happy to provide information about the necessary technology, software and equipment. The file must also include information about colours.
- Any photographs must be attached in TIF or JPG format.
- Text that is to be printed must be specified as running text. Its typeface and any required font size must also be specified. For incomplete files, an additional charge will be made for producing attached files/original. For an hourly charge, Hultafors can also produce an original for the customer as per their specific requirements. A proof consists of one or more blocks that are numbered. These blocks can be used for a subsequent proofing order if, for example, one block is to be replaced whilst the others are to remain.

INVOICING, ADVERTISING PRINT

In addition to the cost for the product, an additional charge will be levied per print and block. In addition, there will be a further charge for any special colours and processing attached originals. Note that for multi-colour prints, printing and blocks will be charged per colour.

PMS

Black	Yellow	Orange	Orange	Red	Pink	Brown	Gray	Green	Dark Green	Turquoise	Light Blue	Blue	Dark Blue
Black	102 c	144 c	165 c	186 c	231 c	478 c	424 c	355 c	343 c	320 c	299 c	293 c	288 c

Advertising Print 59-2-10 RE

Ref. no.	Model	Colour	Print area	Length	Parts	Qty/pack
100009	59-2-10 RE	Natural	140 x 21 mm	2 m	10 pcs	10 pcs
100014	59-2-10 MF	Natural	170 x 4 mm	2 m	10 pcs	10 pcs
100024	59-2-10 F0	Natural	200 x 6 mm	2 m	10 pcs	10 pcs

Metric scale on both sides. Red decimetre figures. Minimum number of folding rules 300.

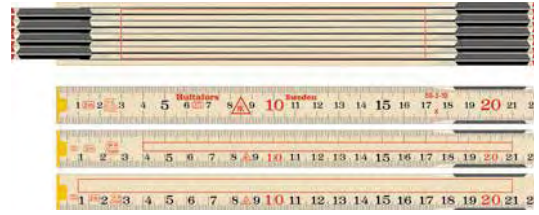

Advertising Print 59-2-12 RE

Ref. no.	Model	Colour	Print area	Length	Parts	Qty/pack
100109	59-2-12 RE	Natural	110 x 27 m	2 m	12 pcs	10 pcs
100114	59-2-12 MF	Natural	147 x 4 mm	2 m	12 pcs	10 pcs
100124	59-2-12 F0	Natural	165 x 6 mm	2 m	12 pcs	10 pcs

Metric scale on both sides. Red decimetre figures. Minimum number of folding rules 300.

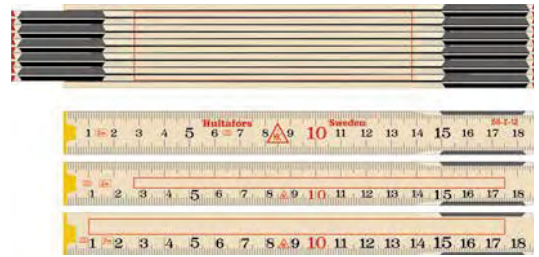

Advertising Print 59-1-6 RE

Ref. no.	Model	Colour	Print area	Length	Parts	Qty/pack
100209	59-1-6 RE	Natural	110 x 10 mm	1 m	6 pcs	10 pcs

Metric scale on both sides. Red decimetre figures. Can only be printed on the sides. Minimum number of folding rules 300.



Advertising Print 61-2-10 RE

Ref. no.	Model	Colour	Print area	Length	Parts	Qty/pack
100509	61-2-10 RE	Natural	140 x 21 mm	2 m	10 pcs	10 pcs
100514	61-2-10 MF	Natural	190 x 6 mm	2 m	10 pcs	10 pcs

Imperial inches on upper edge and metric scale on lower edge on both sides. Minimum number of folding rules 300.



Advertising Print 61-1-6 RE

Ref. no.	Model	Colour	Print area	Length	Parts	Qty/pack
100709	61-1-6 RE	Natural	110 x 10 mm	1 m	6 pcs	10 pcs

Imperial inches on upper edge and metric scale on lower edge on both sides. Can only be printed on sides. Minimum number of folding rules 300.



Advertising Print 559-2-10 RE

Ref. no.	Model	Colour	Print area	Length	Parts	Qty/pack
101809	559-2-10 RE	Natural	140 x 21 mm	2 m	10 pcs	10 pcs

Internal scale on both sides. Decimetre figures in red. Can only be printed on sides. Minimum number of folding rules 300.

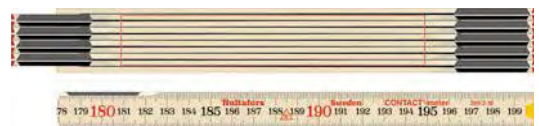

Advertising Print G59-2-10 RE



Ref. no.	Model	Colour	Print area	Length	Parts	Qty/pack
200009	G59-2-10 GU RE	Yellow	180 x 24 mm	2 m	10 pcs	10 pcs
200069	G59-2-10 VI RE	White	180 x 24 mm	2 m	10 pcs	10 pcs

Metric scale on both sides. Decimetre figures in red. Can only be printed on sides. Minimum number of folding rules 300.

ADVER. PRINT GE59-2-10 RE



Ref. no.	Model	Colour	Print area	Length	Parts	Qty/pack
200669	GE59-2-10 VI RE	White	180 x 24 mm	2 m	10 pcs	10 pcs
200609	GE59-2-10 GU RE	Yellow	180 x 24 mm	2 m	10 pcs	10 pcs

Metric scale on both sides. Decimetre figures in red. Can only be printed on sides. Minimum number of folding rules 300.

Advertising Print G59-1-10 RE

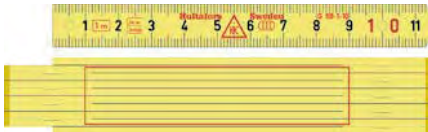

Ref. no.	Model	Colour	Print area	Length	Parts	Qty/pack
200309	G59-1-10 GU RE	Yellow	90 x 17.5 mm	1 m	10 pcs	10 pcs
200369	G59-1-10 VI RE	White	90 x 17.5 mm	1 m	10 pcs	10 pcs

Metric scale on both sides. Decimetre figures in red. Can only be printed on sides. Minimum number of folding rules 300.

Advertising Print G59-2-12 RE

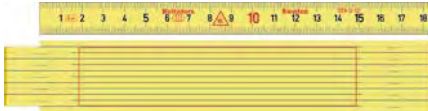

Ref. no.	Model	Colour	Print area	Length	Parts	Qty/pack
200109	G59-2-12 GU RE	Yellow	130 x 27 mm	2 m	12 pcs	10 pcs

Metric scale on both sides. Decimetre figures in red. Can only be printed on sides. Minimum number of folding rules 300.

Advertising Print G59-1-6 RE



Ref. no.	Model	Colour	Print area	Length	Parts	Qty/pack
200209	G59-1-6 GU RE	Yellow	130 x 10 mm	1 m	6 pcs	10 pcs

Metric scale on both sides. Decimetre figures in red. Can only be printed on sides. Minimum number of folding rules 300.

Advertising Print G61-2-10 RE



Ref. no.	Model	Colour	Print area	Length	Parts	Qty/pack
200409	G61-2-10 GU RE	Yellow	180 x 24 mm	2 m	10 pcs	10 pcs

Imperial inches on upper edge and metric scale on lower edge on both sides. Can only be printed on sides. Minimum number of folding rules 300.

Advertising Print G61-1-6 RE



Ref. no.	Model	Colour	Print area	Length	Parts	Qty/pack
200509	G61-1-6 GU RE	Yellow	130 x 10 mm	1 m	6 pcs	10 pcs

Imperial inches on upper edge and metric scale on lower edge on both sides. Can only be printed on sides. Minimum number of folding rules 300.

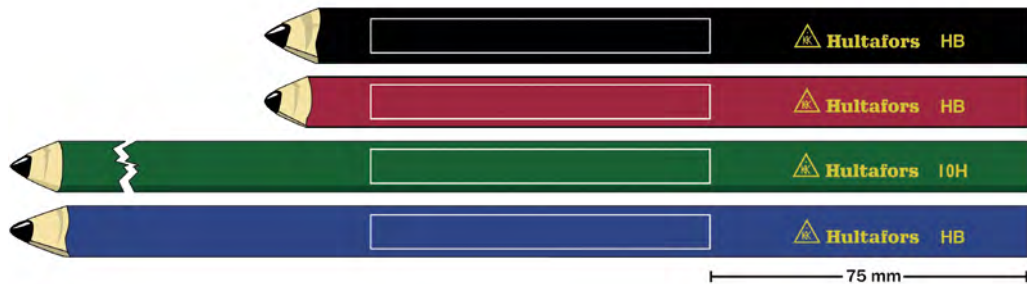

Advertising Print Pencils

Print area 80x8 mm. Positioned 75 mm from the end of the pencil. Minimum quantity 600.

Ref. no.	Model	Length	Hardness	Print area	Qty/pack
650209	SNP 18 RED RE	180 mm	HB	80 x 8 mm	200 pcs
650709	SNP 18 BLACK RE	180 mm	HB	80 x 8 mm	200 pcs
650409	SNP 24 BLUE RE	240 mm	HB	80 x 8 mm	200 pcs
650309	BEP 30 GREEN RE	300 mm	10 H	80 x 8 mm	200 pcs

Advertising Print Knives

Available print area depends on knife model. Minimum quantity 300.

Ref. no.	Model	Print area 1	Print area 2
380019	HVK	25x10 mm	62x19 mm
380219*	HVK GH	25x10 mm	62x19 mm
380069	RFR	25x10 mm	62x19 mm
380269*	RFR GH	25x10 mm	62x19 mm
380089**	SK	25x15 mm	62x19 mm
380099**	SKR	25x15 mm	62x19 mm
380049***	MK	25x10 mm	62x19 mm
380059***	VVS	25x10 mm	62x19 mm

*Registered Community Design No. 001152821-1/2

**Registered Community Design No. 000857214-1/6

***Registered Community Design No. 000245022-1/2

Ref. no.	Model	Print area 1	Print area 2
380029	GK	30x14 mm	62x19 mm
380079	STK	30x14 mm	62x19 mm

Ref. no.	Model	Print area 1	Print area 2
380039	ELK	25x15 mm	18x19 mm



HANDSAW HBS - Advertising print

A standard handsaw with fiberglass reinforced handle and a 1 mm thick steel blade. Minimum number of handsaws 90 pcs.

Ref.No.	Model	Blade length	Blade length	Teeth/ inch	Print area	Qty/pack
590729	HBS-22-7 RE	550 mm	22 inch	7	200 x 58 mm	10 pcs
590726	HBS-22-7 RE	550 mm	22 inch	7	200 x 58 mm	45 p stcs



HULTAFORS GROUP

IN EVERY WAY, A PARTNER TO RELY ON.

A UNIQUE PRODUCT FAMILY

HULTAFORS **GROUP** offers a dynamic range of premium brands to rely on – for distributors and craftsmen alike. Each brand within the Group is united with a common passion: to keep craftsmen at the forefront in terms of functionality, safety, protection and overall productivity.

Each brand represents expertise in its particular area and brings unparalleled knowledge and insight into the unique on-the-job challenges encountered by craftsmen. This makes it possible for us to meet, even anticipate, evolving demands by designing innovative state-of-the-art products that make the craftsmen's workday safer, easier and more productive.

Excelling in brand-driven product categories within the industry and construction equipment sectors, we offer

customers and users a best-in-class experience. And by using our high-value products as well as benefitting from brands built around their needs, craftsmen can be at the forefront every day and take great pride in their work.

Hultafors Group consists of Snickers Workwear, Wibe Ladders, Hultafors, Solid Gear, Toe Guard and Dunderdon – six leading brands that together offer a unique product family for professional craftsmen.

Snickers Workwear

– WEAR THE DIFFERENCE.

Snickers Workwear is one of the leading brands in the workwear industry in Europe and is represented in more than 20 countries. Snickers Workwear offers advanced workwear for craftsmen who want the ultimate in on-the-job safety, protection and functionality.

Solid Gear

– ONE STEP AHEAD.

Solid Gear provides utility footwear for professional workers. We insist on nothing less than perfection and make sure that every detail counts. Step into our shoes and experience true passion for shoe making.

Hultafors

– TO RELY ON.

Hultafors is a leading international brand offering innovative state-of-the-art hand tools with the best possible functionality, precision and reliability. Designed for construction and industry.

Dunderdon

– THE PRODUCT MAKES THE BRAND.

Offering honest, timeless and casual design. Dunderdon's products should represent the highest craftsmanship and innovation, while never compromising on fit and style.

Wibe Ladders

– SAFETY IN EVERY STEP.

Wibe Ladders is the leading Nordic manufacturer of innovative tradesmen's ladders, trestle steps and scaffolding that help trade professionals work more safely and efficiently.

Toe Guard

– SAFETY WITHOUT COMPROMISE.

The Toe Guard brand represents safety without compromise, timeless design and affordable products. Our aim is to offer great products at competitive prices.

hultaforsgroup.com

HULTAFORS TOOLS IN EUROPE

HEAD OFFICE, SWEDEN

Box 38
517 21 Bollebygd
Tel. +46 (0)33 723 74 00
Fax +46 (0)33 723 74 10
info@hultaforsgroup.com

AUSTRIA

Administered from the
German national office.
Im Meisenfeld 26
32602 Vlotho
Tel. +49 (0)5228 957 0
Fax +49 (0)5228 957 112

BELGIUM

Snickers Original NV
Antwerpsesteenweg 285
2800 MECHELEN
Tel. +32 (0)15 44 65 30
Fax +32 (0)15 44 65 39

CROATIA

Morlak d.o.o.
Lindlarska 19
21215 Kastel Luksic (Split)
www.morlak-doo.hr
Tel. +385 (0)21/228-245
Fax +385 (0)21/261-210

CZECH REPUBLIC AND SLOVAKIA

AC-T servis, spol. s r.o.
Náchodská 61
193 00 Praha 9
Czech Republic
Tel. 00420 281 926 244
Fax 00420 281 926 244
info@profi-odevy.cz
www.profi-odevy.cz

DENMARK

Hultafors Group Denmark A/S
Energivej 37
2750 Ballerup
Tel. +45 44 86 06 00
Fax +45 44 86 06 06

ESTONIA

Tamrex Ohutuse OÜ
Laki 5
10621 Tallinn
www.tamrex.ee
Tel. +37 2 654 9900
Fax +37 2 654 9901

FINLAND

Hultafors Group Finland Oy
Konalantie 47 F
00390 HELSINKI
Tel. +358 (0)20 741 0130
Fax +358 (0)20 741 0148

FRANCE

Snickers Workwear France SARL
59 Rue des Petits Champs
75001 Paris
Tel. +33 (0)1 53 40 89 90
Fax +33 (0)1 53 40 89 89

GERMANY

Hultafors Group Germany GmbH
Im Meisenfeld 26
32602 Vlotho
Tel. +49 (0)5228 957 0
Fax +49 (0)5228 957 112

HUNGARY

KLÍMA-EXPRESS KFT
H-1104. Budapest
Bodza u. 2.
www.munkaruha-munkacipo.hu
Tel. +36 1 260 3950
Fax +36 1 262 0758

HUNGARY

Safety Systems Hungária Kft.
H-1149 Budapest
Mogyoródi út 32
www.svedmunkaruha.hu
www.sshshop.hu
Tel. +36 1 784 7079
Fax +36 1 799 4294

IRELAND

Snickers Workwear Ltd
Unit B5, Calmount Park
Ballymount
DUBLIN 12
Tel. +353 (0)1 409 8400
Fax +353 (0)1 409 8499

LATVIA

SIA Tamrex
Maskavas iela 328
LV-1063 Rīga
www.tamrex.lv
Tel. +371 660 65 265
Fax +371 660 65 267

LITHUANIA

UAB Tamrex
Savanorių pr. 191
LT-02300 Vilnius
www.tamrex.lt
Tel. +370 52671799
Fax +370 52100040

THE NETHERLANDS

Snickers Original BV
Postbus 20077
7302 HB APELDOORN
Tel. +31 (0)55 599 98 60
Fax +31 (0)55 599 98 70

NORWAY

Hultafors Group Norge AS
Postboks 108
0582 OSLO
Tel. +47 23 06 88 80
Fax +47 22 16 49 80

POLAND

Hultafors Group Poland Sp. z o.o.
ul. Nowogrodzka 50/515
00-695 Warszawa
Tel. +48 22 29 51 287
Fax +48 22 30 01 285

PORTUGAL

Flexiwear, Lda
Travessa de São Pedro, lote B
2660-335 Stº António dos
Cavaleiros
www.flexiwear.com.pt
Tel. +351 211 554 561
Fax +351 211 305 520

SLOVENIA

BMC d.o.o.
Pod javorjji 5
1218 Komenda
www.delovnaoblacila.si
Tel. +386 183 13 156
Fax +386 183 15 630

SPAIN

AT - Snickers Workwear
Labradores, 11
Pol. Ind. Prado Espino
28660 Boadilla del Monte,
MADRID
www.at-snickersworkwear.es
Tel. +34 91 633 44 50
Fax +34 91 632 07 15

SWITZERLAND

Hultafors Group Switzerland AG
Gaswerkstrasse 32
CH-4900 Langenthal
Tel. +41 (0)62 923 62 81
(German)
Tel. +41 (0)62 923 62 82
(French)
Fax +41 (0)62 923 62 85

UK

Snickers Workwear Ltd
Unit N3, Gate 4,
Meltham Mills Ind Estate, Meltham
HOLMFIRTH HD9 4DS
Tel. +44 (0)1484 85 44 88
Fax +44 (0)1484 85 47 33
toolsinfo@snickersworkwear.co.uk

OTHER MARKETS

Administered from Sweden
Box 989
191 29 SOLLENTUNA
Tel. +46 (0)8 92 51 00
Fax +46 (0)8 92 51 98
info@hultafors.se

Hultafors Tools Product Development reserve the right
to make improvements and alternatives to products,
product ranges and materials without notification and
on an ongoing basis.

The content of this publication is subject to copyright
and may not be copied or reproduced.

CONCEPT: VALENTIN&BYHR.
PRODUCTION AND REPRO: PRODUKTIONSBYRÅN MEDLEY.
FOTO: ROB VANSTONE, HENRIK SANDSJO, MAGNUS PAJNERT, JERRY HULL.
PRODUCT PHOTOGRAPHY: MATS JOHANSSON, GOTHIA REKLAMFOTO, BORÅS
OSKAR ARVIDSSON, GRAFIA, GÖTEBORG & JAN HÅKANSSON, CLICK PHOTO, NÄSSJÖ.
PRINTING: ALFREDSSON COMMUNICATION. DECEMBER 2015. ART. NO. 99830000003

